

16" X 72" 18 GA. HOLD DOWN PLATE  
 4'-0 3/8" X 1 1/4" X 1/4" STRAPPING (3)  
 3" X 3/8"-16 BOLTS  
 CHANNEL  
 2" POLYSTYRENE PANEL  
 2 lb. DENSITY WITH ALUMINUM EXTERIOR BOTH SIDES  
 DETAIL ON NEXT PAGE

**NON-DIVING POOL  
 USE OF DIVING EQUIPMENT  
 IS PROHIBITED**

LEGEND	
A- FRAME BRACE (TYP)-	

**ALL DIMENSIONS ARE FINISH DIMENSIONS**

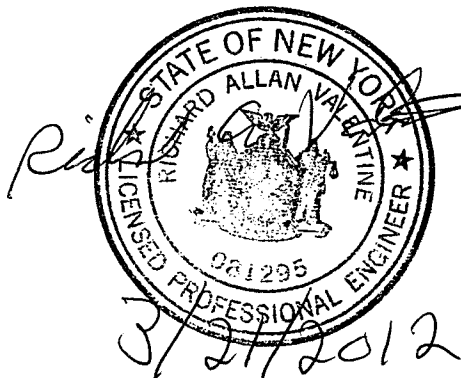

	440 NORTH PEARL STREET ALBANY, NY 12207 PHONE:(518) 434-4161 FAX:(518) 432-6554	<b>12 X 24 METRIC OVAL</b>				
		DATE: 12.15.11	PERIMETER: 61'-8 3/8"	AREA: 257.1 sq.ft.	GALLONAGE: 7,051.8 gal.	DEALER: XXXXXX
		CUSTOM FEATURES		DRAWN BY: DAVE	CHECKED BY: XXXXXX	CUSTOMER: XXXXXX
		PART NO. XXXXXXXX	SCALE NTS	FILE NAME: XXXXXX	XXXXXX	

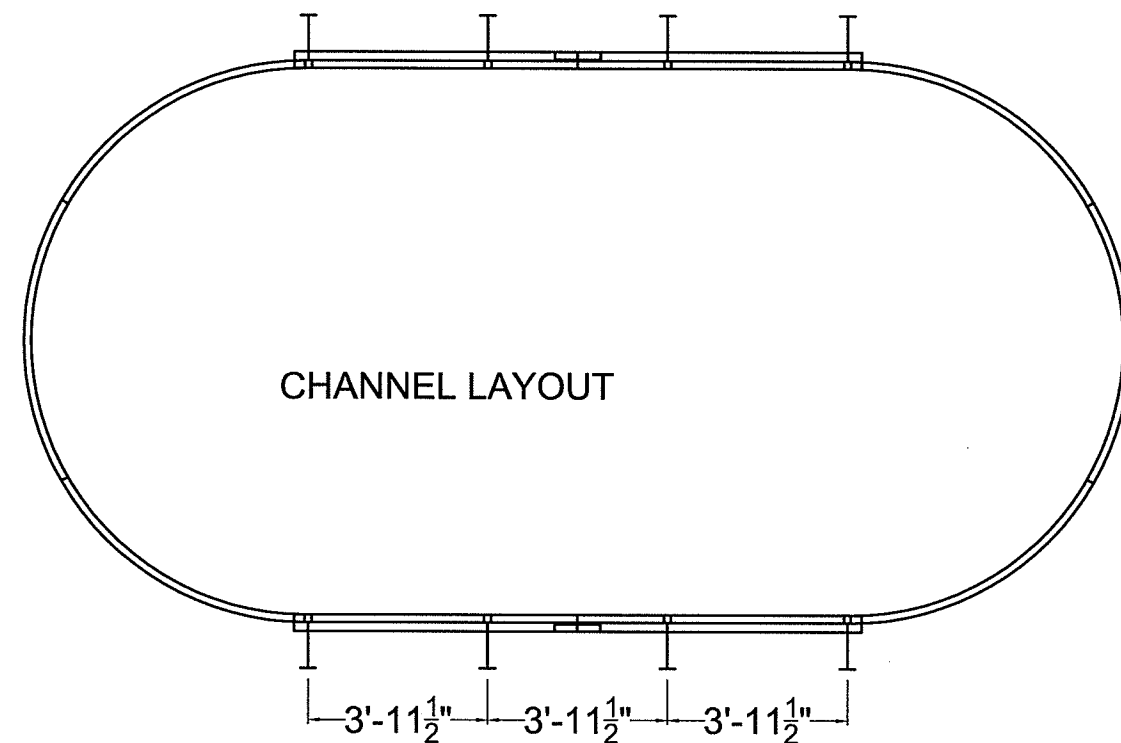
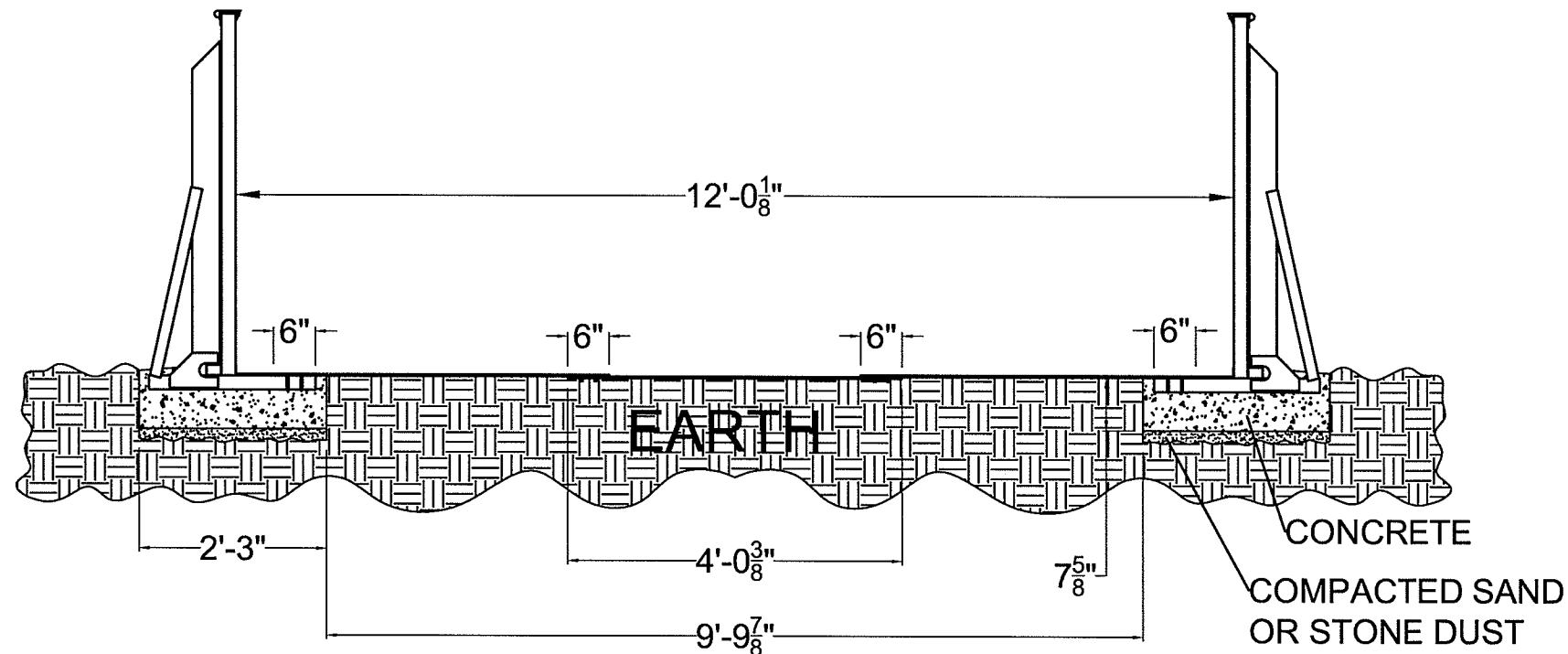
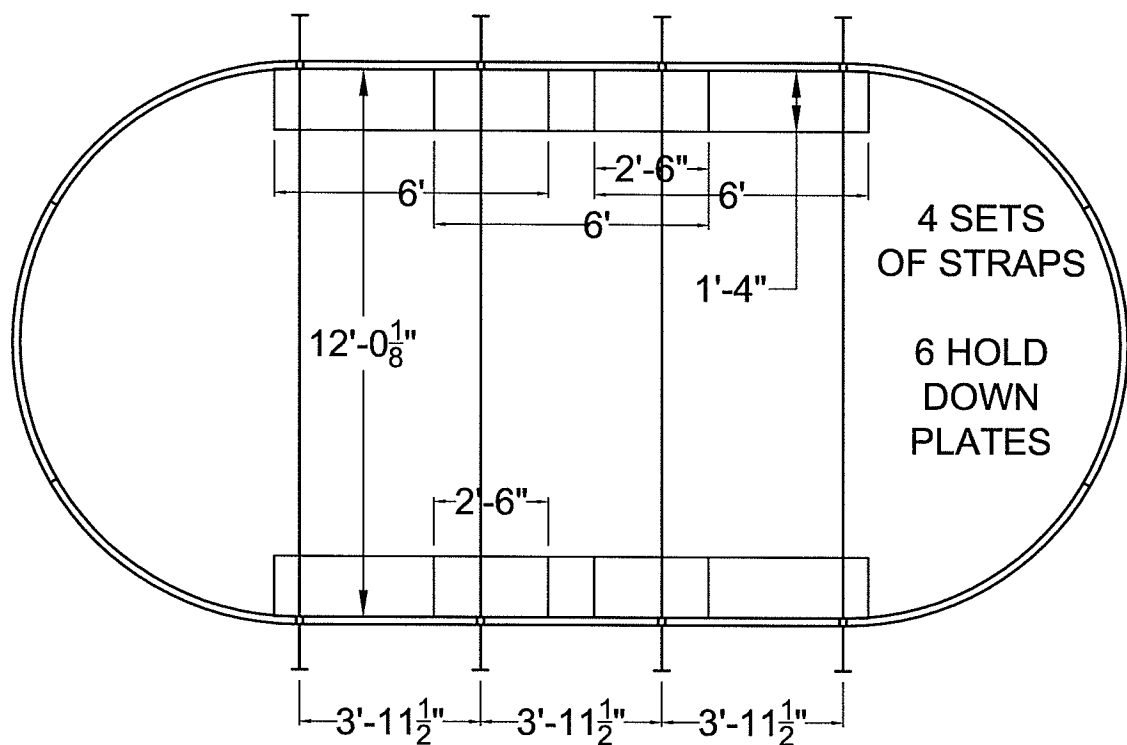

**ENGINEER NOTES:**

- 1) ALL INSIDE DIMENSIONS ARE FINISHED DIMENSIONS.
- 2) CONSTRUCTION METHODS AND PRECAUTIONS ARE DICTATED BY GROUND AND SOIL CONDITIONS TO BE DETERMINED BY THE CONTRACTOR, WHO IS NOT AN AGENT OR EMPLOYEE OF RADIANT POOLS OR THE MANUFACTURER OF THE POOL COMPONENTS.
- 3) INSTALLATION IS TO BE DONE IN ACCORDANCE WITH THE MORE STRINGENT OF ALL FEDERAL AND LOCAL CODES, AS WELL AS THE APSP CODES AND MANUFACTURERS INSTRUCTIONS.
- 4) ALL DRAWINGS ARE NOT TO SCALE UNLESS OTHERWISE NOTED
- 5) ALL COMPONENTS OF THIS PROJECT MUST BE IN ACCORDANCE WITH THE LATEST EDITIONS OF APPLICABLE LOCAL AND STATE CODES, THE NATIONAL ELECTRIC CODE, OSHA REQUIREMENTS AND THE LIFE SAFETY CODE.
- 6) SURFACE ON WHICH POOL WILL STAND MUST BE ABSOLUTELY LEVEL AND SOLID

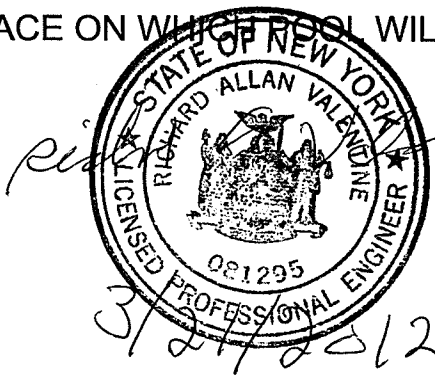

	440 NORTH PEARL STREET ALBANY, NY 12207 PHONE:(518) 434-4161 FAX:(518) 432-6554		<b>12 X 24 METRIC OVAL</b>			
	DATE: 12.15.11	PERIMETER: 61'-8 <sup>3</sup> / <sub>8</sub> "	AREA: 257.1 sq.ft.	GALLONAGE: 7,051.8 gal.	DEALER XXXXXX	
	CUSTOM FEATURES			DRAWN BY: DAVE	CHECKED BY: XXXXXX	CUSTOMER XXXXXX
	PART NO. XXXXXXXX	SCALE NTS	FILE NAME: XXXXXX	XXXXXX		