

Installation Manual

Inground Residential Swimming Pool

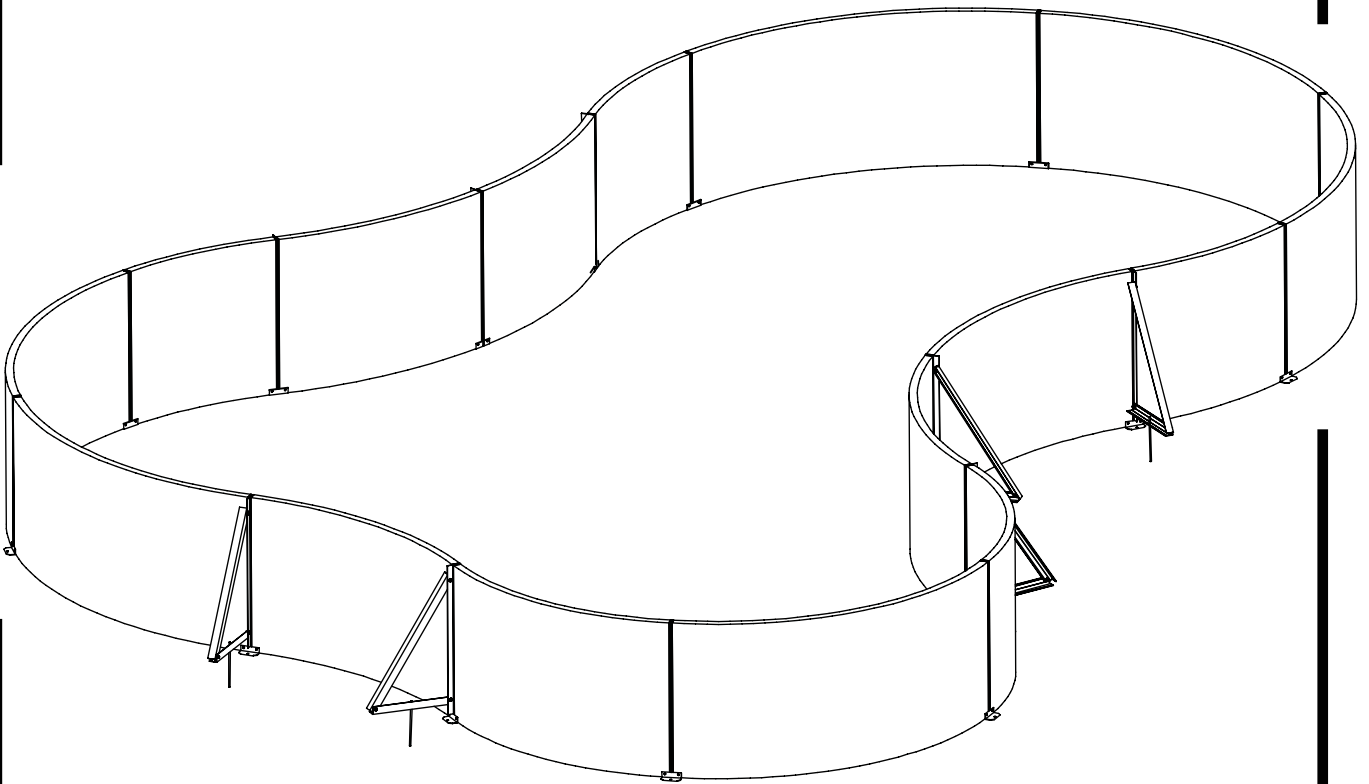

Radiant
A Latham Pool Company

IMPORTANT SAFETY INFORMATION

Enclosed in the liner box is the safety envelope. The safety stickers must be installed as per instructions. Failure to properly install warning labels will void warranty. Alert all visitors and family of the risks associated with jumping and/or diving and point out all warning labels supplied. Failure to mount these safety labels may subject you to substantial liability in case of injury.

Your pool is designed for years of pleasurable, safe family fun. But when used incorrectly, a swimming pool can be dangerous. To insure your pool is used safely you must observe the following safety precautions:

1. Do not dive, do not jump, no rough play, no running or pushing.
2. Be sure to install all safety labels provided with your pool according to the safety instructions.
3. Keep a 50' safety rope with a flotation buoy with an outside diameter of 15" accessible in a prominent area by your pool.
4. Post near all entrances to the pool area a list of telephone numbers for the following:
 - a. Local police
 - b. Local fire department
 - c. Local rescue unit
 - d. Local ambulance service
 - e. Local hospital
 - f. 911 emergency number, if available
5. Provide fencing or an enclosure which is independent of the house as a closure around the entire pool area. The fencing must be made of durable material, a minimum of 4' high from ground level and with closures with self-latching locks to make the pool inaccessible to toddlers and uninvited guests. Make sure the gate is always closed. Be sure to follow local building code requirements for load capacity and fencing if using an aftermarket or home built deck.
6. Check with your local town or municipality in regard to obtaining a building permit and/or an electrical permit. The installer shall follow the regulations for set backs, barriers, devices and other conditions.
7. All electrical outlet connections should be a minimum of 5' from the outside perimeter of the wall of the pool. From 5'-10' there should be either a fixed connection (outlet box) or twist lock connection with a GFCI. Connect power cords to a 3-wire grounding-type outlet only.
8. Severe electrical shock could result if you install your pump or filter on a deck. They could fall into the water causing severe shock or electrocution. Do not install on a deck or other surface at, above or slightly below the top ledge of the pool, within 5 feet of pool water edge.
9. Do not sit, stand or climb on the pump and filter or any part of the pool structure. Components such as the filtration system, pumps and heater must be positioned so as to prevent their being used as a means of access to the pool by young children.
10. Never drink alcoholic beverages or use any intoxicants which could hinder your judgment and reflexes.
11. Never use the pool alone. All children must be supervised continuously.
12. Do not use pool if bottom is not clearly visible. At night, sufficient lighting must be available. It is the pool owners' sole responsibility to provide adequate lighting for the pool bottom, safety signs and walkways, which exceeds minimum standards of the IES of North America.
13. Be sure that all toys, chairs and tables or similar objects that a young child could climb on be at least 4' from the pool.
14. Do not use pool during electrical or rain storms.
15. See available Association of Spa and Pool Professionals (APSP) publications for more tips on pool safety.

TOOLS and MATERIALS NEEDED

Tape measure, 100ft.

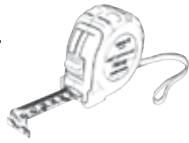

Orange Marking Spray Paint



Metal File



Transit/Laser Level



Utility Knife



Hose with spray nozzle

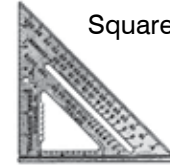

Square



String



Level



Duct Tape



Cloth rag



Rubber Mallet



Cooking Spray

Long handled pointed shovel



Step Drill Bit



Short handle square shovel



Socket Set



Hacksaw

Pick or Mattock



9/16" Open End Wrench



Power Drill



1/4" Hex nut driver bit



Tamper, 10 or 12 in. Square

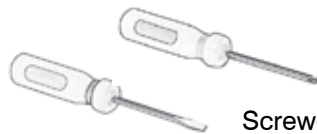
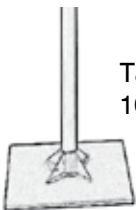

Screwdrivers, Flathead and Phillips

7/16" and 1/8" Drill bits



Pool trowel



14" Channel Locks

Extension Cord



Shop Vac



Rake

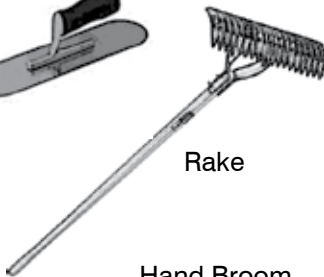

PVC Pipe Cutter



Foam Sealant (Great Stuff)



Masonry Sand



Hand Broom



2x4



2" Patio Block

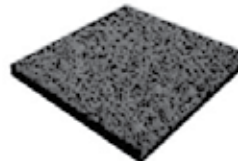

Wheelbarrow



Soft bristle broom



INTRODUCTION

The Installation of the Radiant Inground pool is not hard, nor complicated. Although installation conditions might differ from this guide, it is important to consult with the manufacturer before making any changes that might disturb the integrity of the pool. Failure to follow these instructions will void all warranties. Read and follow all manufacturers' instructions including accessories such as pumps, filters, skimmers, etc. prior to starting.

Before you start, check your packing list to confirm that you have the correct number of parts and components. The manufacturer reserves the right to revise, change or modify construction of its pools. See packing list for pool components included for your pool. If there are any missing or damaged components, please contact your retailer for replacement.

While all Radiant pools are designed to meet or exceed industry recommended safety standards (*ANSI/APSP-4 and 5 American National Standards for Residential Swimming Pools*), special attention must be paid to all installation procedures that the installer performs and controls. Spend time to ensure that the entire pool framework is **perfectly level and square**. Unlevel pools place extreme pressures on the pool walls. Be sure to follow these instructions. Improperly installed pools can rupture, allowing thousands of gallons of water to rush out causing extensive property damage and injury to anyone in its path. As with any major home project, a homeowner is responsible for following all local laws, ordinances and codes. Electrical grounding of swimming pool is required. National and local codes must be followed. A checklist is provided below as a guide for these considerations.

✓ HOMEOWNER CHECKLIST	
<input type="checkbox"/>	Obtain building permit if required.
<input type="checkbox"/>	Local building and zoning requirements
<input type="checkbox"/>	Electrical and Grounding requirements
<input type="checkbox"/>	Have Ground Tested for Stray Electricity
<input type="checkbox"/>	Proper Backfill and Drainage
<input type="checkbox"/>	Fencing requirements
<input type="checkbox"/>	Backwash (waste water) requirements
<input type="checkbox"/>	Check availability of utilities.
<input type="checkbox"/>	Call before you dig (www.digsafe.com)
<input type="checkbox"/>	If pool has steps, read the step manual.
<input type="checkbox"/>	Disposal of excavation materials

With proper installation, care and maintenance, this Inground Residential Swimming Pool from Radiant Pools will provide a lifetime of fun and relaxation for the homeowner.

Radiant Pools offers a non-prorated, lifetime guarantee on the entire pool against manufacturing defects. Walls, coping, structural supports, and channels are guaranteed against defects due to faulty workmanship or manufacturing for as long as you own your home. Compare our warranty with any other pool manufactured. Engineering, innovation and efficiency make the difference. It's simply brilliant.

IMPORTANT: BEFORE YOU BEGIN

The selection and preparation of the pool site is your responsibility. The manufacturer can only suggest the proper techniques, indicate the important considerations and emphasize the precautions and cannot be held responsible for damages to your pool that may result from failure to carefully follow all pool specifications.

All Radiant Pool components are engineered to provide a precise fit. It is very important to handle all components with care. Prior to assembly, all pool components should be free of sand, mud, dirt and debris of any kind.

We recommend a small broom or shop-vac to maintain a clean track system throughout the installation process. In addition we recommend a damp cloth be available in the event that any dirt or debris finds its way to the panel surface.

STRAIGHT PANEL POOL COMPONENTS WITH 90° CORNERS

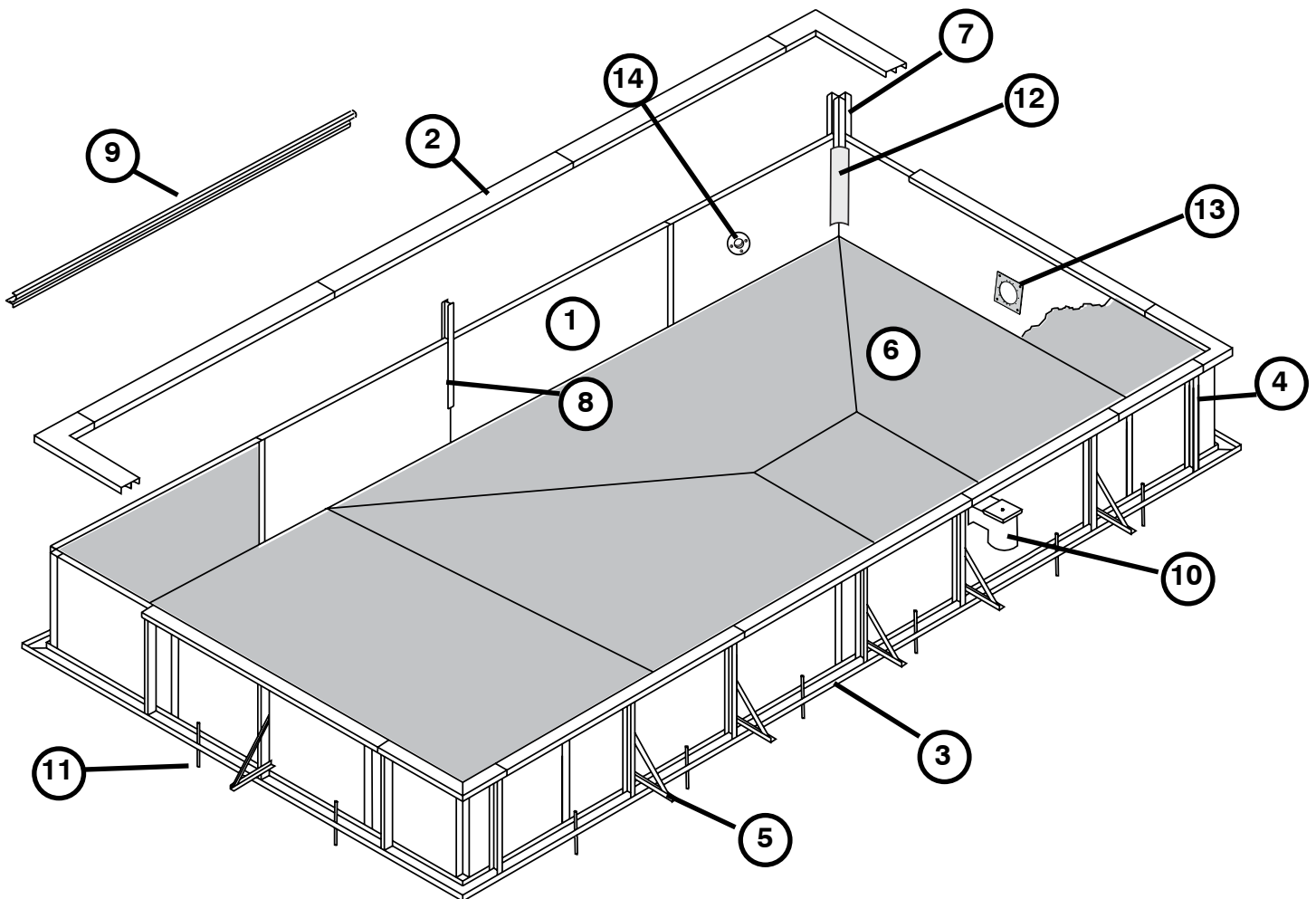

#	COMPONENT
1	Straight Wall Panel - Form straight sides of pool.
2	Top Channel - Support top of straight walls and provide attachment for coping.
3	Bottom Channel - Provide base and structural support for straight walls.
4	Backbraces - Connect top & bottom channels together.
5	A-Frames - Fasten to backbraces & imbedded in concrete for stability.
6	Liner - Fits inside of pool to form a watertight skin.
7	Corner Connector - Used at corner joints to join walls together.
8	Panel Connector - Join straight panels together.
9	Concrete Receptor Coping (optional) - Secures liner & gives finished appearance.
10	Skimmer Assembly
11	15" Rebar - to stabilize bottom channel
12	6" Radius Corner Filler - for smooth liner transition in corners
13	Light Niche Mounting Plate
14	Return Fitting

STRAIGHT PANEL POOL COMPONENTS WITH 45° CORNERS

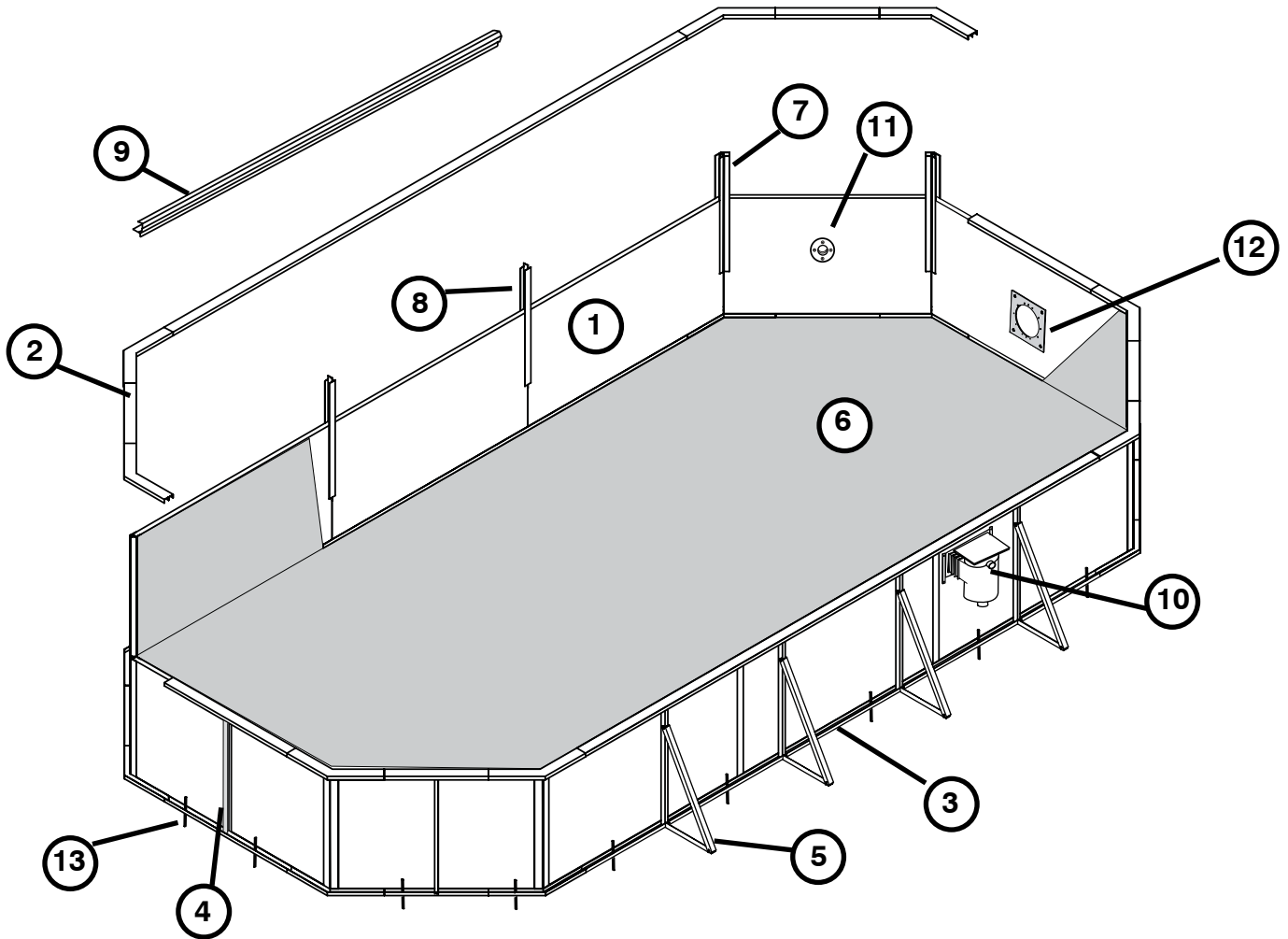

#	COMPONENT
1	Straight Wall Panel - Form straight sides of pool.
2	Top Channel - Support top of straight walls and provide attachment for coping.
3	Bottom Channel - Provide base and structural support for straight walls.
4	Backbraces - Connects top & bottom channels together.
5	A-Frames - Fasten to backbraces & imbedded in concrete for stability.
6	Liner - Fits inside of pool to form a watertight skin.
7	45° Corner Connector - Used at corner joints to join walls together.
8	Panel Connector - Join straight panels together.
9	5/4 Wood Receptor Coping (optional) - Secures liner, receives decking
10	Skimmer Assembly
11	Return Fitting
12	Light Niche Mounting Plate (optional)
13	15" Rebar - to stabilize bottom channel

RADIUS PANEL POOL COMPONENTS

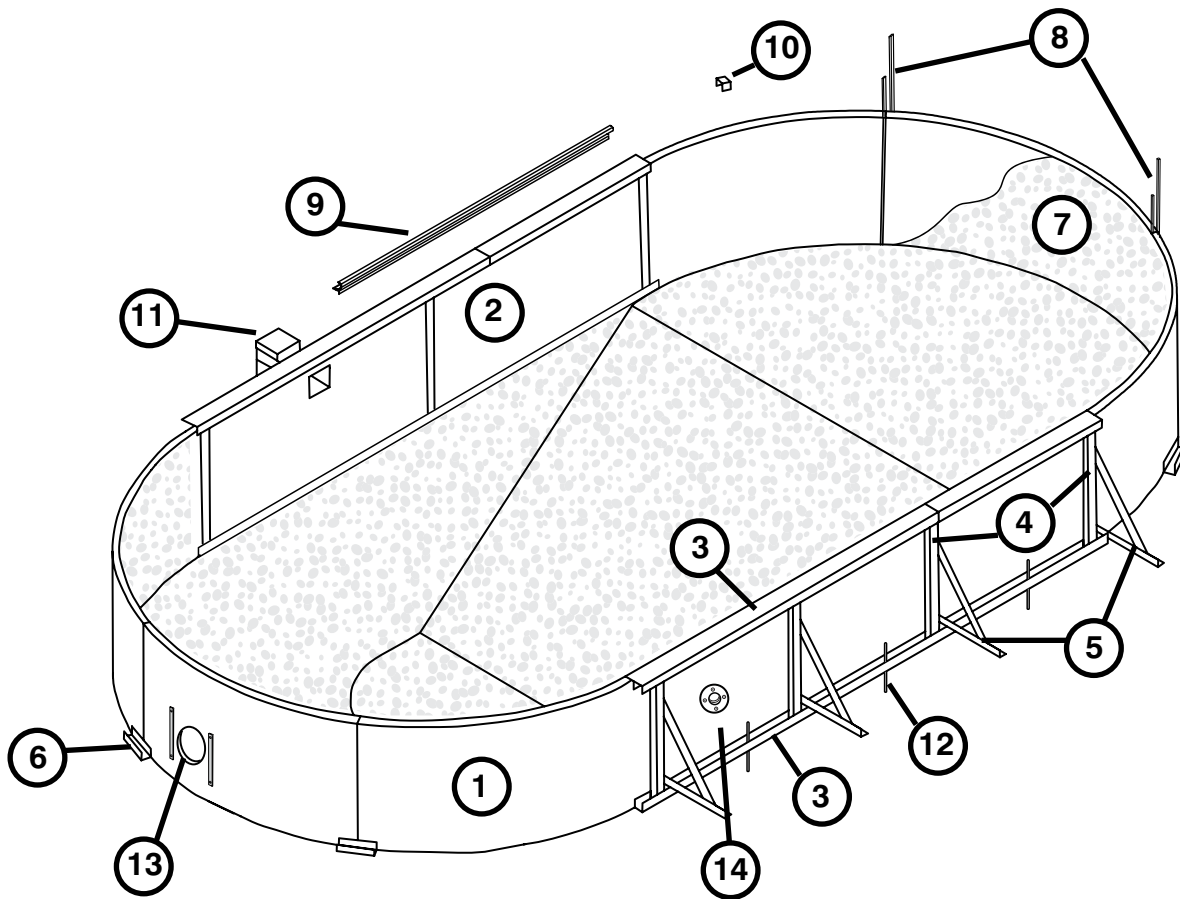

#	COMPONENT
1	Curved Wall Panel - Form curved ends of pool.
2	Straight Wall Panel - Form straight sides of pool.
3	Channel- Support top and bottom of straight walls.
4	Backbraces - Connects top & bottom channels together.
5	A-Frames - Fasten to backbraces & imbedded in concrete for stability.
6	Anchors - Bolt to walls & imbedded in concrete for additional strength.
7	Liner - Fits inside of pool to form a watertight skin.
8	Splines - Used at all panel joints to join walls together.
9	Concrete Receptor Coping - Secures liner & gives finished appearance.
10	Wall Clip - Spaced evenly, secures receptor coping to curved panels.
11	Skimmer Assembly
12	15" Rebar - to stabilize bottom channel
13	Light Niche Mounting Assembly (Optional)
14	Return Fitting

RADIUS PANEL POOL COMPONENTS

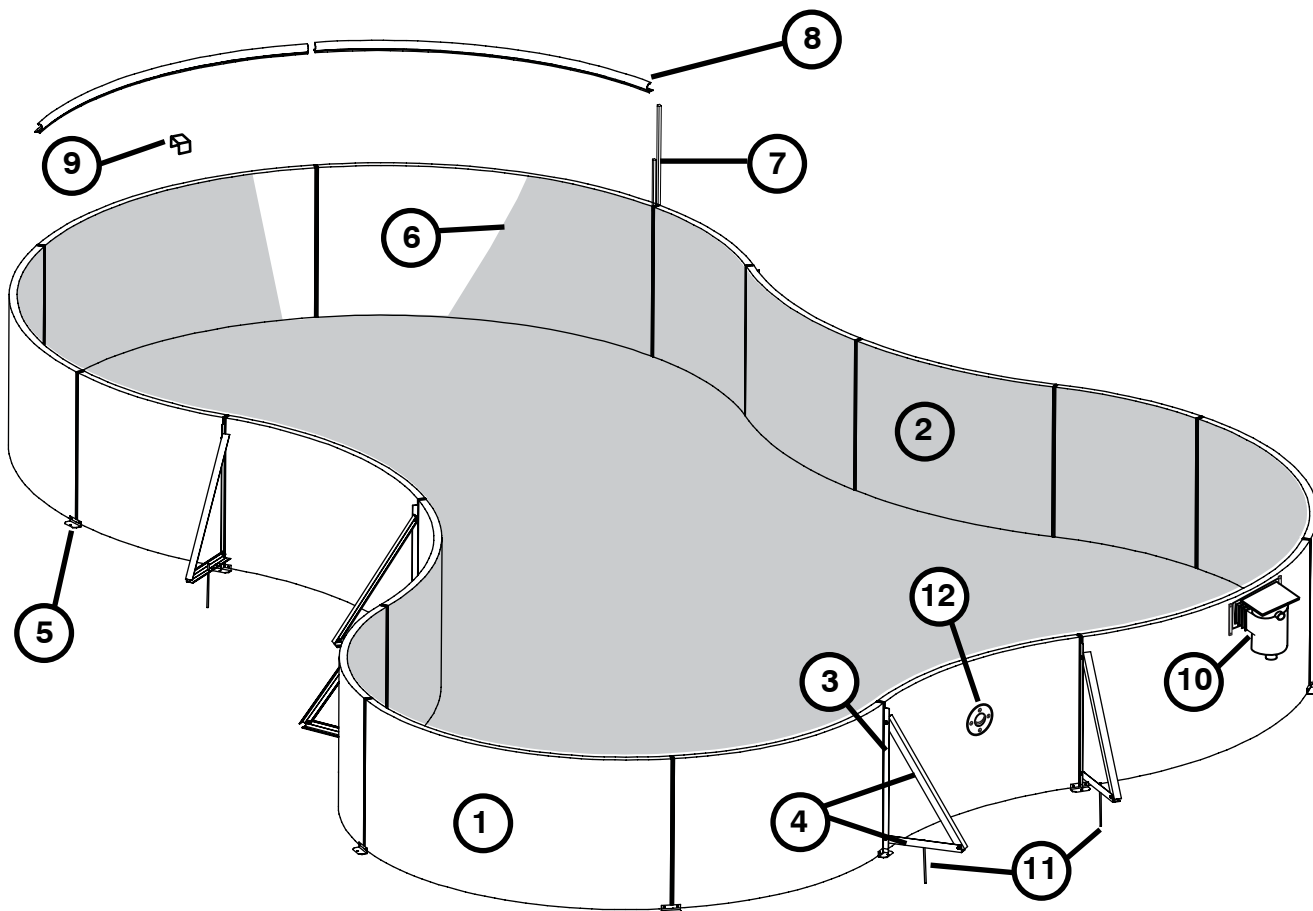

#	COMPONENT
1	Standard Radius Wall Panel
2	Reverse Radius Wall Panel
3	Extended Spline - Connects to horizontal and diagonal A-frame.
4	A-Frames - Fastens to Extended Spline & imbedded in concrete for stability.
5	Anchors - Bolt to walls & imbedded in concrete for additional strength.
6	Liner - Fits inside of pool to form a watertight skin.
7	Splines - Used at all panel joints to join walls together.
8	Concrete Receptor Coping - Secures liner & gives finished appearance.
9	Wall Clip - Spaced evenly, secures receptor coping to curved panels.
10	Skimmer Assembly
11	15" Rebar - to stabilize bottom channel
12	Return Fitting

LEVELING THE EXCAVATION

Layout the pool outline on the ground relative to ground obstacles and structures near by. Mark the overdig for excavation 24" outside the pool outline. The overdig is soil or dirt to be removed for access for the pool supports, concrete collar, and work room outside the pool walls. Mark location for skimmer(s), inlets, step, light and any other accessories to be installed. Check for buried or overhead obstacles, electricity, plumbing, septic lines etc.

Note: An 8' step will need an extra 6' x 10' area to be excavated. Please see the dig specifications for location options for the steps.

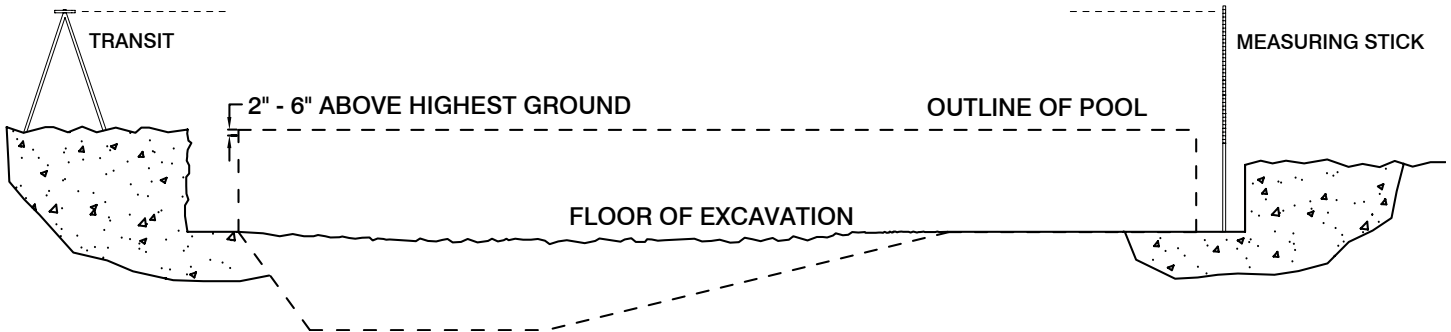

Determine the height of pool relative to ground and surrounding structures. Pool should be set at height (Benchmark) so that rain and splash will drain away from the pool (1" for every 4'). The benchmark must include wall height, coping and added decking.

A sturdier pool will result when the pool rests on undisturbed earth. It is better to have to remove an inch or two by hand than to have to build up after the excavation went too deep. Any voids beneath the wall panels caused by large rock removal, etc., must be filled and properly compacted.

The dig specification drawings indicate the wall height and finish depth inside and deep end of a pool. An 8' hopper excavation is a minimum of 8' 2". A 42" wall outside will be 40" inside under the liner finish depth.

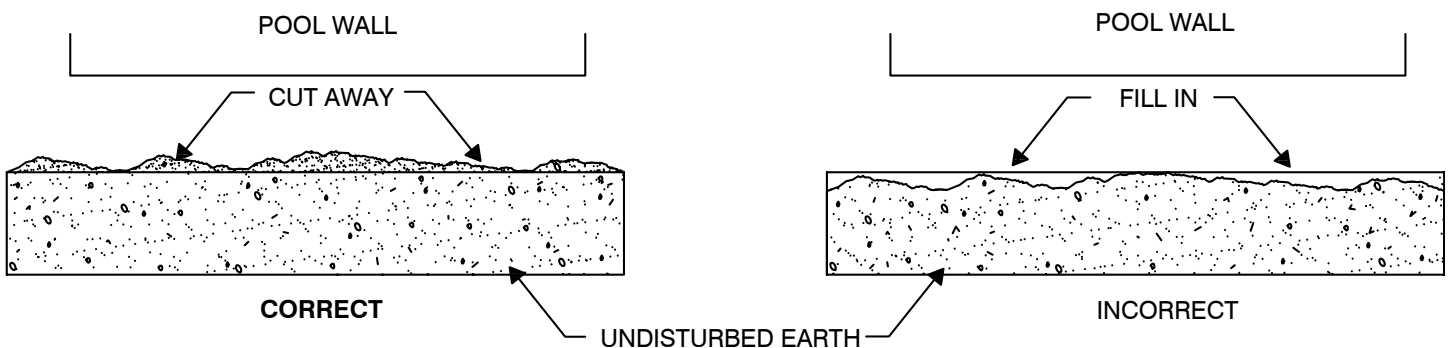

Note: if installing steps in a freeform pool (no straight walls), begin the panel installation at both sides of the step and continue assembly from there.

CHANNEL ASSEMBLY

Straight wall pools utilize aluminum channel to create a framework for all remaining assembly.

To assemble, align the holes on one side of the extension tab over holes in channel track. Insert 3/8" bolts with 9/16" head with washers from beneath the bottom track using open end wrench. Continue by aligning the next bottom channel piece with the holes on the other side of the tab. Again insert included bolts and attach with head and washers. **DO NOT OVERTIGHTEN!** For top channel, insert bolts with washers from above the channel.

Check bottom track for cleanliness. Track should be free of all dirt and debris before inserting wall panels. Check that the bottom track is square. (See Dig Specifications for dimensions for specific shapes/sizes) The measurements from point "A" to point "C" and from point "B" to "D" should be the same.

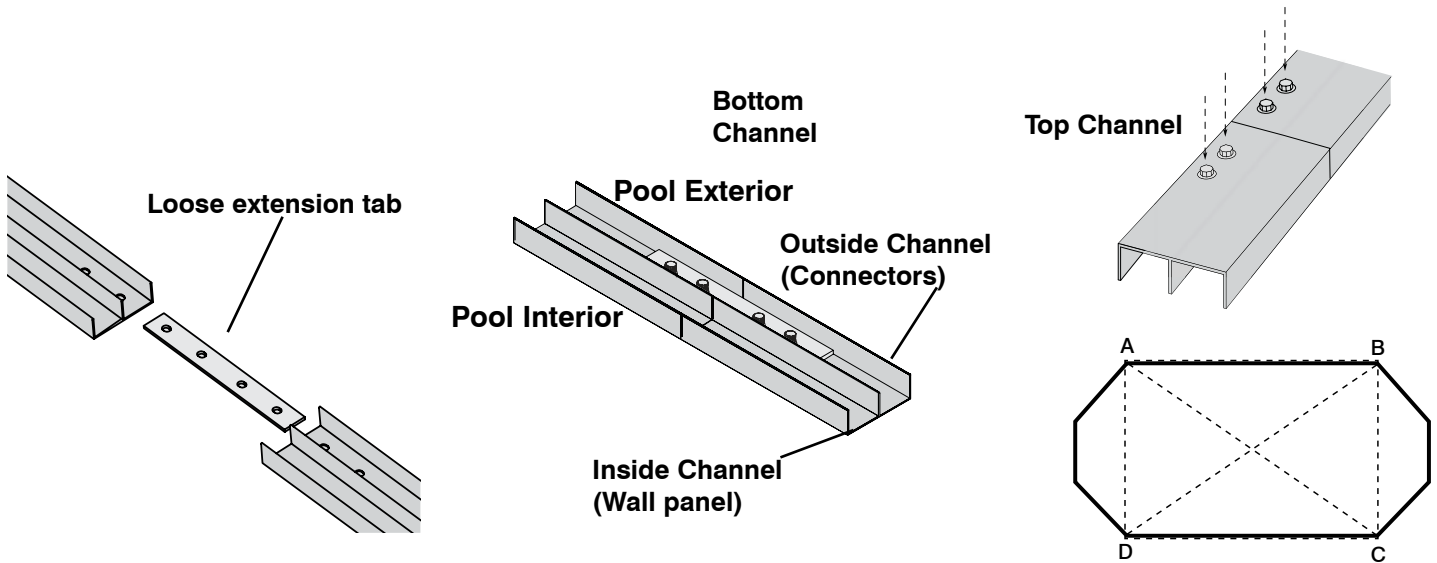

WALL PANEL CONNECTION ASSEMBLY

Be sure that bottom channel and wall panels are free of debris before beginning assembly.

Once bottom track is assembled, begin installing wall panels. On straight wall pools, always start with the end corner connections first, working towards the middle as shown. It is important that the final panel assembled is a straight panel connection. As wall panels are assembled, install top channel per channel assembly instructions above.

On pools with a combination of straight and radius panels, such as the Oval and Kidney shapes, it is recommended that the straight wall panels be assembled first.

For all radius panel pools, wall panel installation can begin at any point on the pool. However, it is important to keep in mind that you should not end assembly at a regular radius to reverse radius panel connection, as this will make finishing the wall assembly extremely difficult.

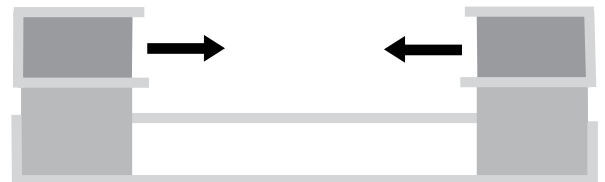
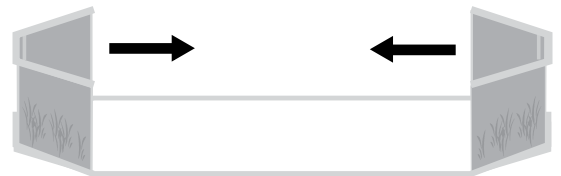

WALL PANEL CONNECTION ASSEMBLY

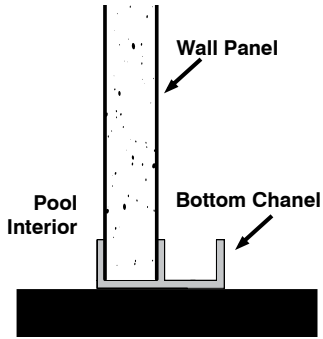

Insert panels in bottom channel in pool interior side of track as shown below. When connecting the 45° corners, make sure to align the center of the connector with the angle of the bottom track. These must be properly aligned or installation of subsequent panels will be difficult.

Connecting Panels at 45° Corners

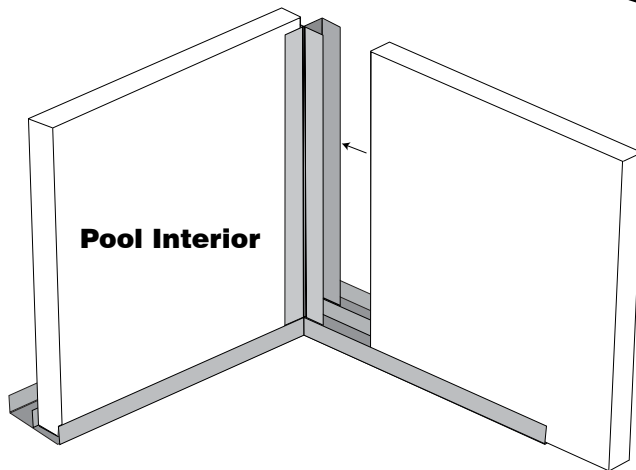
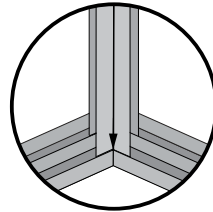
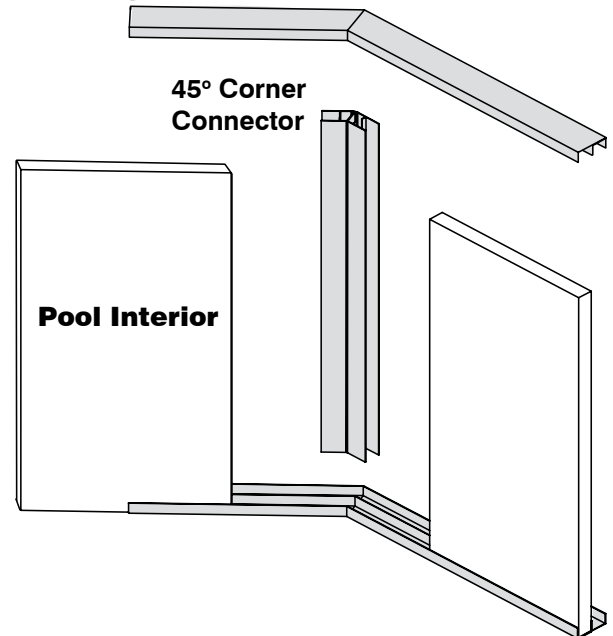

Connecting Panels at 90° Corners

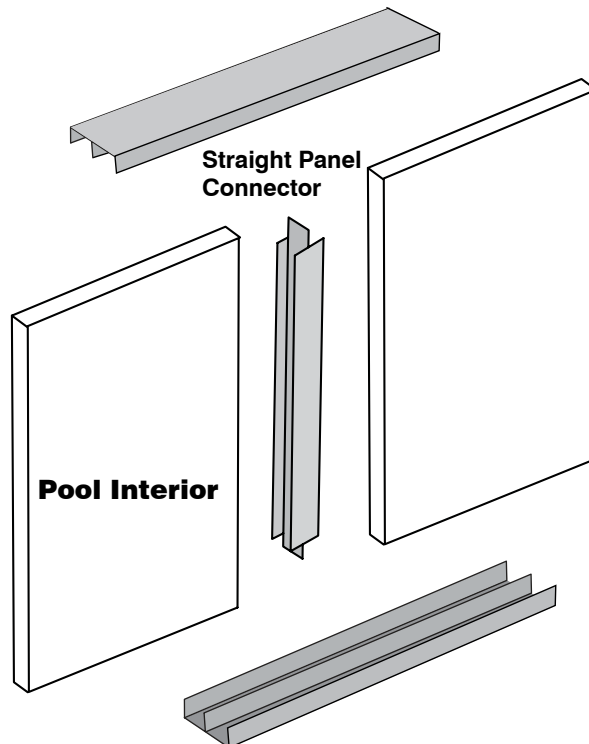
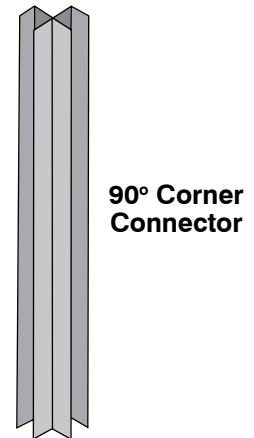

Connecting Straight Panels

When corner panels on both ends are assembled, begin with the straight panel assembly, working towards the middle as indicated on page 10. Slide panels into bottom track, connecting as shown at left.

Continue this process with the remaining wall panels stopping before installing the final wall panel.

WALL PANEL CONNECTION ASSEMBLY

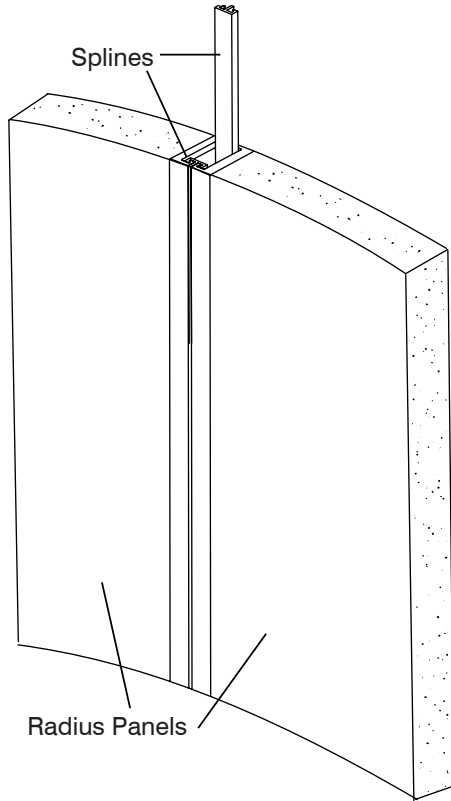

Connecting Radius Panels

At the end of each radius panel is a compression seam for the spline assembly. Attach wall sections using the provided splines. Place an anchor plate centered on a patio block. Place 2 wall panels so they meet on the center of the anchor plate. Please be aware that each compression seam should be flush before attempting to insert the splines. Splines are designed to slide freely into place when inserted properly into leveled panels. Gently shaking the panels may help ease insertion of some of the splines.

Note: Use cooking oil or food spray as a lubricant on the first 4-6" of the splines. Do not use petroleum based lubricants (WD-40).

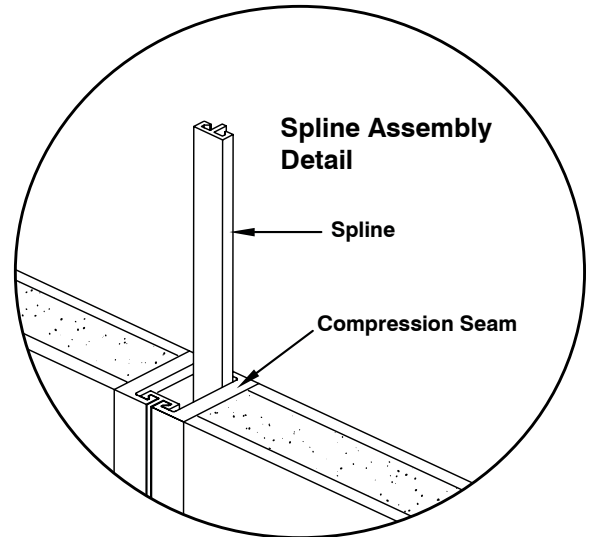

Hard downward pressure or hammering causes metal burrs and jams the spline into the compression seam. If a compression seam does not go easy, leave it and go to the next one or next panel. Aligning the next panel will most frequently align the previous one as well.

With the anchor plate centered under the seam, drill 7/16" holes through the bottom of the pool panels using the predrilled holes in the anchor plates as a guide. Secure with 2 - 1/2" bolts and nuts. Make sure the panels are securely in the anchor plates and even at the top before drilling. **(fig. B)** This will create a bolted pool frame to meet continuity requirements in the National Electrical Code.

Note: Oval and Kidney pool channel is 6" longer than the straight panels. The radius panels will extend into the channel 3" to attach to the straight panel with standard splines.

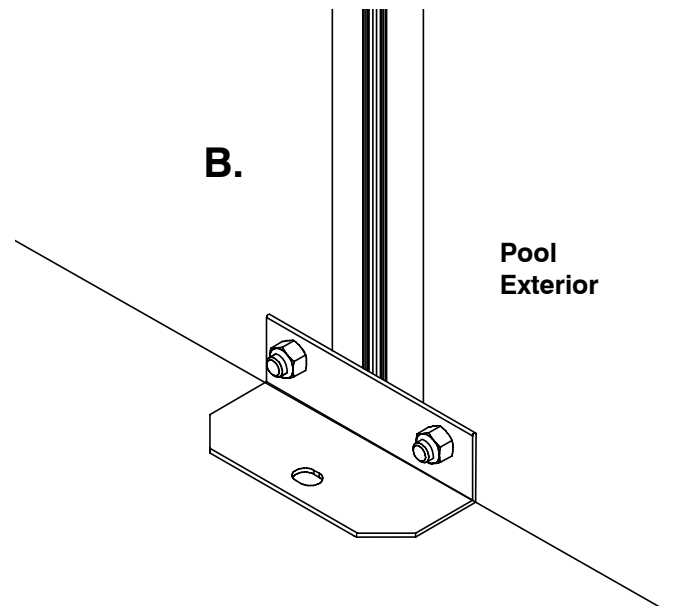

WALL PANEL CONNECTION ASSEMBLY

Extended Spline Installation for Connecting Reverse Radius to Radius Panels

Place an anchor plate centered on a patio block. Place 2 wall panels so they meet at the center of the anchor plate. Slide standard spline inside and extended spline outside into place as shown. With a 42" panel, the Extended spline will cover the complete wall height. Panels with a height of 48", will have a 5 3/4" regular spline on top and a 52" panel will have a 10" standard spline installed on top of the extended spline.

Secure with 2 1/2" bolts and nuts in anchor plates. Make sure the panels are securely in the anchor plates and even at the top before drilling. This will create a bolted pool frame for bonding, if needed. Assemble the A-Frame to the extended spline with 3/8" x 3/4" hex bolts and nuts.

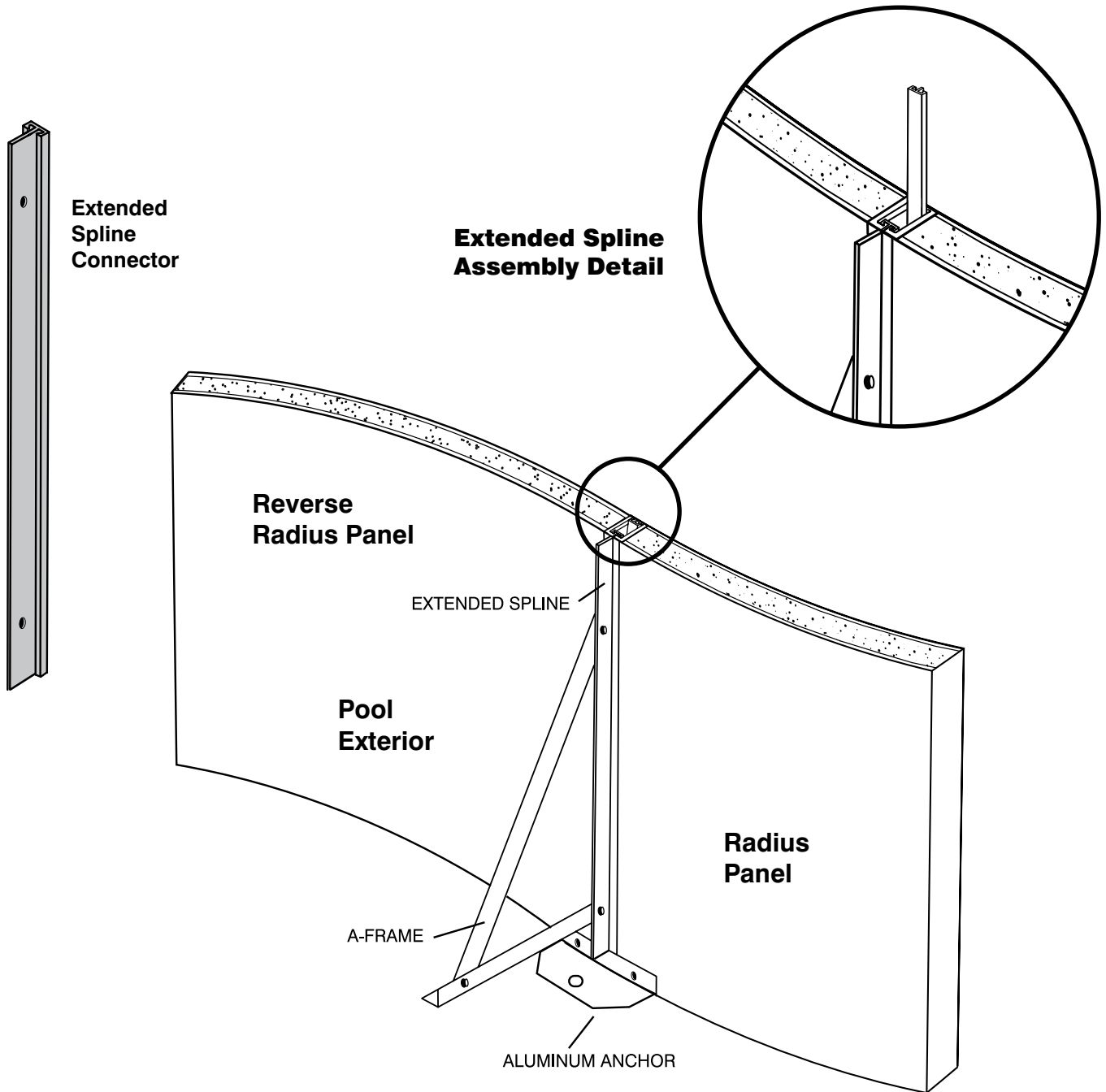

A-FRAME & BACKBRACE CONSTRUCTION

Position backbraces and attached A-Frames in their proper locations around the pool. Please Refer to the dig specifications for spacing and placement. The backbrace is bolted to the top and bottom channel, the diagonal and bottom horizontal A-Frame parts are bolted together then to the backbraces.

Every backbrace will not have an A-Frame. With the Radiant inground pool an A-Frame is not necessary at a panel joint or to level the pool before pouring the concrete collar.

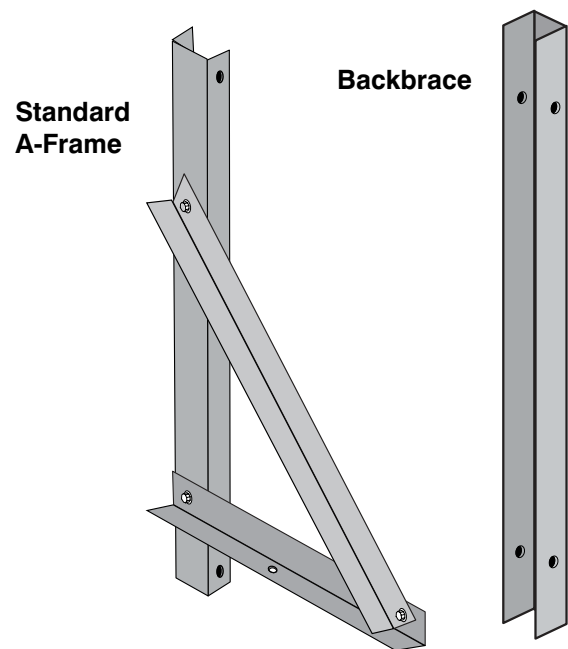
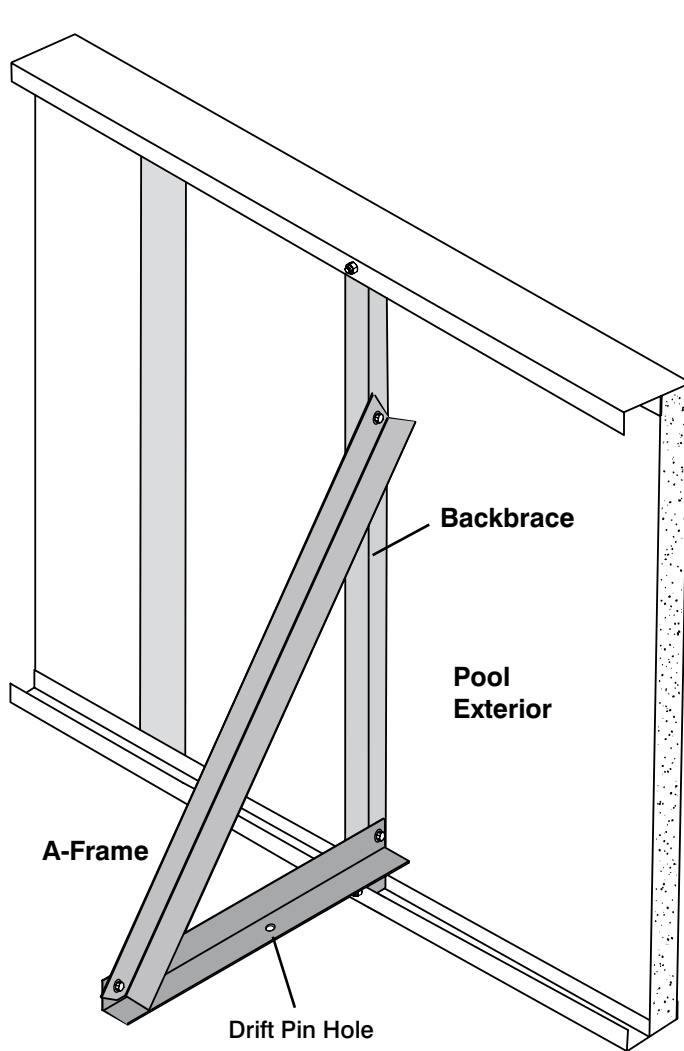

The bottom of the A-Frame is 2" to 4" off the ground to better encase the A-Frame in the concrete collar. Drive a drift pin down through the pre-drilled hole in the horizontal of the A-Frame.

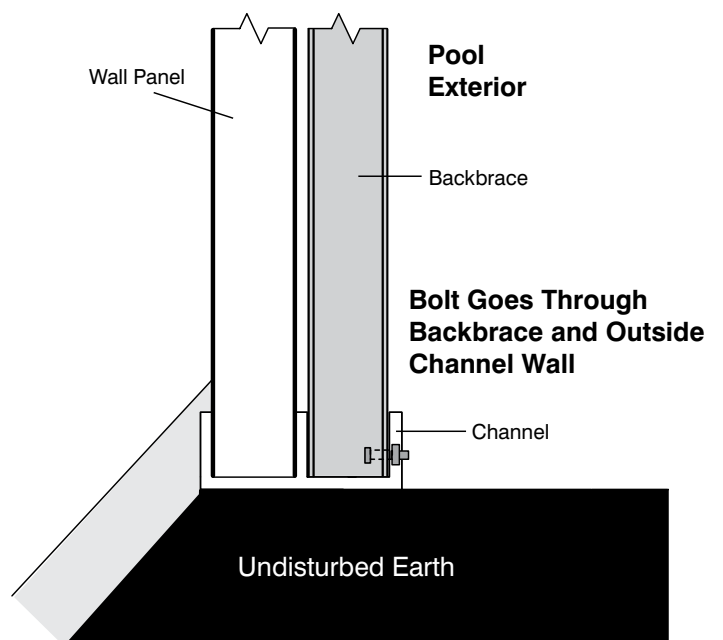

COPING CONNECTION

Wall Clips and Coping On Curved Panels

Paver coping installation must start with Radiant Nassau wall clips. They provide a hard surface on the top of the wall on which to attach the coping. Paver coping is notched to accommodate standard radii.

Place Nassau clips on the wall every 12". Do not Tek screw to the wall yet as final placement will vary with coping length.

Place Paver coping lengths on wall panel with a Nassau wall clip centered at the beginning and end of the length. Secure the wall clips to the panels and the coping to the wall clips with Tek screws on the exterior side of pool.

The next length is placed adjacent to the end of the first length, continuing around the pool. If you are installing a walk-in step, start at the step and continue around the pool, cutting the last length to fit. When all lengths are installed, apply a barrier between the bottom of the coping and the top of the pool wall to prevent sand and debris from getting in behind the liner. Silicone, foam sealant or duct tape can be used.

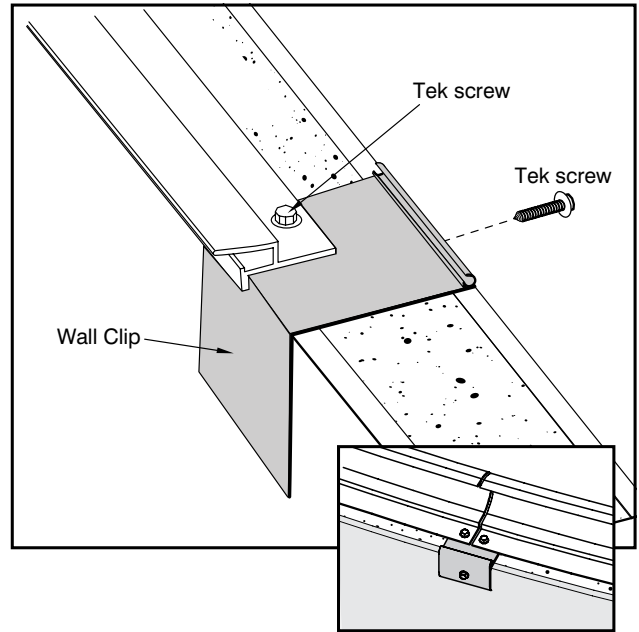

Straight Panel Coping Connection

The straight wall pools with top channel do not use the wall clips. Coping is Tek screwed directly to the top channel.

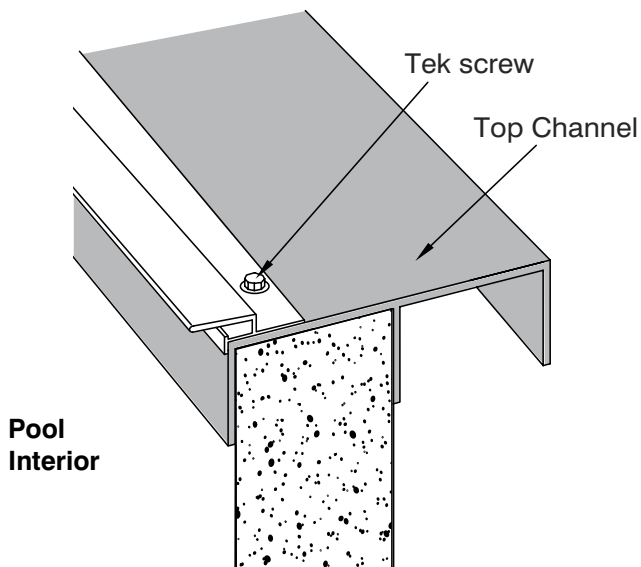

As with straight wall panel assembly, it is recommended that coping installation start at the corners first.

RADIANT CONCRETE RECEPTOR COPING

Radiant Concrete Receptor Coping (RCR) installation must start with Radiant Nassau Wall Clips. They provide a hard surface on the top of the wall on which to attach the coping. RCR Coping is notched to accommodate standard radii (Pre-formed 6" radius and Grecian Corners are available).

Place Nassau Clips on the wall every 12" to 18". Do not Tek screw to the wall yet as final placement will vary with coping length.

Place RCR Coping on wall panel with a Nassau wall clip centered at the beginning and end of the length. To bend notched coping, slowly pull the coping to the desired radius as you work your way down the bar. Begin securing one end of the coping with Tek screws, Nassau Wall Clips, Support Anchors and Coping Clips where needed. Use a white rubber mallet to aid in forming the coping to the final radius as you work your way down the bar. Once the desired final radius is met, secure Nassau wall clips to the pool wall and the coping to the wall clips every 12" and Support Anchors every 2 1/2'-3'.

RCR Coping
Part # 3324-N (notched)
3324-S (straight)

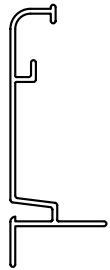

Support Anchor
Part # 3324-A

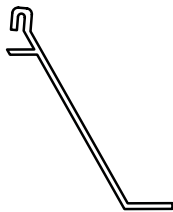

Coping Clip
Part # 3324-C

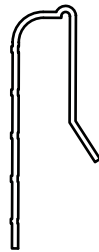

Nassau Clip
Part # 1712



Figure A.

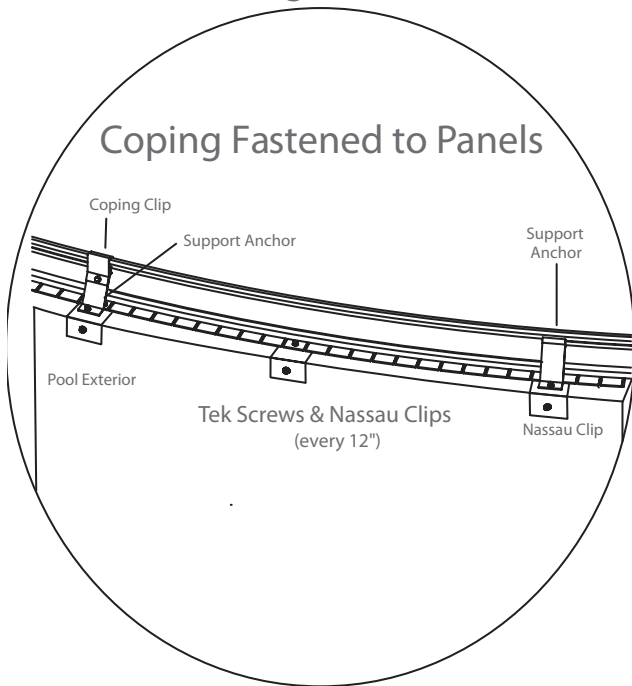
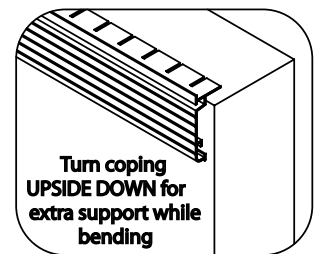
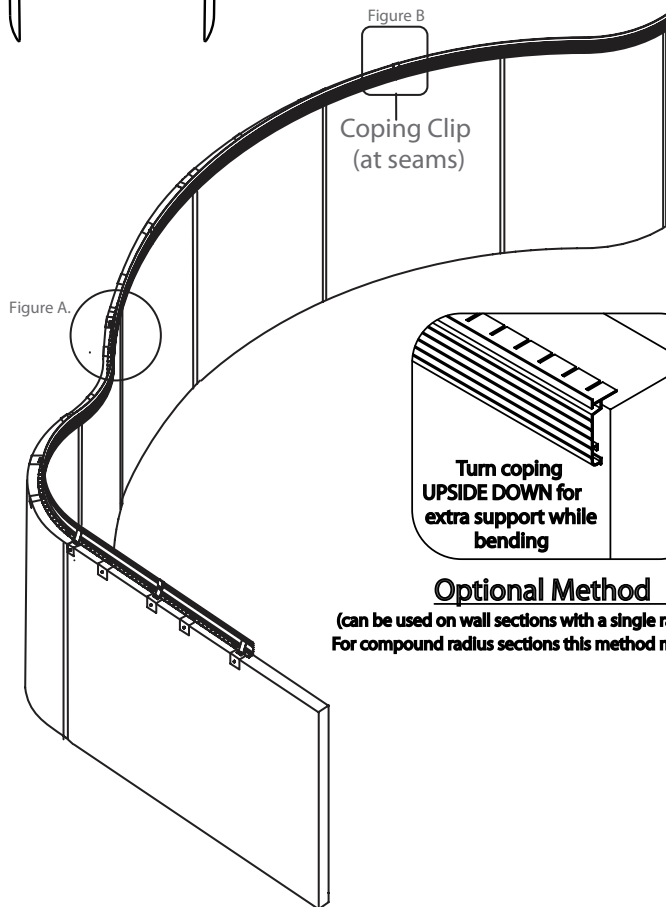
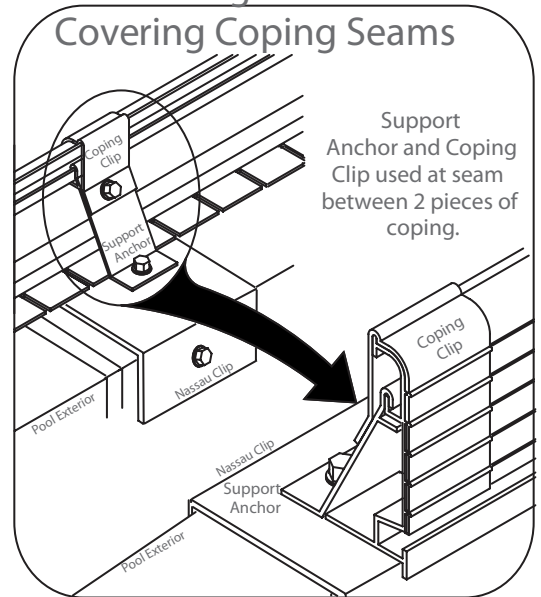

Figure B.
Covering Coping Seams



Optional Method

(can be used on wall sections with a single radius to form. For compound radius sections this method may NOT work)

RADIUS PANEL: SKIMMER ASSEMBLY

Mount the aluminum skimmer plate (fig. A) to the inside pool wall and the white plastic mounting plate (fig. B) to the outside pool wall using the included nuts and bolts. Keep all connections slightly loose to ensure correct skimmer placement.

Mount inground skimmer to the aluminum skimmer mounting plate using the included screws. Now securely tighten nuts and bolts on mounting kit and cover edges of aluminum plate with duct tape.

Position one gasket (fig. C) on the sealing surface of the skimmer and secure tightly with duct tape. When dropping the liner, you may want to install the liner bead around skimmer locations last, in order to avoid disturbing gasket placement.

After liner has been installed and water level approaches skimmer, prep skimmer faceplate (fig. D) by lining up faceplate and gasket, and then carefully drive screws through faceplate, gasket, liner, interior gasket and into skimmer throat. Securing the corners first will help ensure correct placement.

As water level approaches skimmer, carefully cut out liner from inside of skimmer faceplate with sharp blade, making sure to avoid nicking the gaskets.

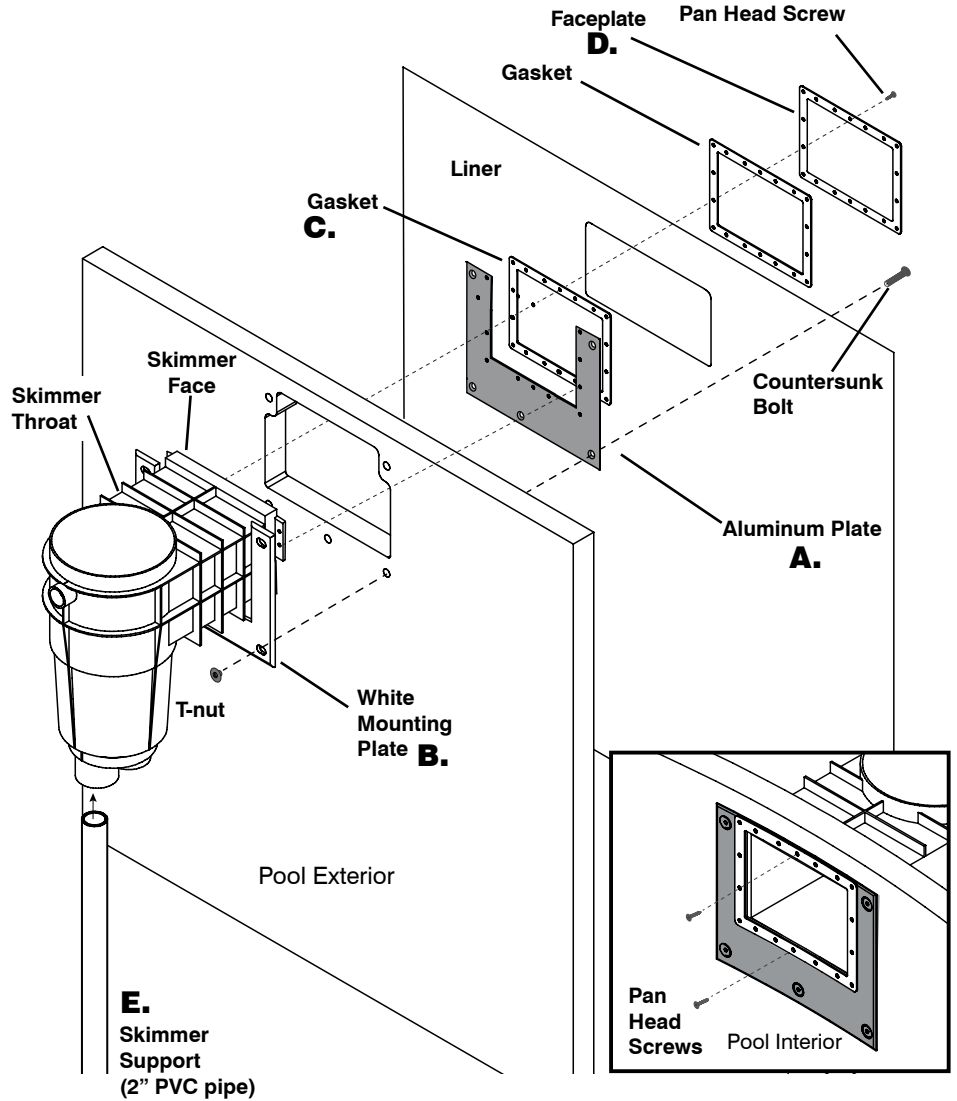

Notes: It is recommended that 2" Schedule 40 PVC pipe be cut to size, depending on installation. Plug unused skimmer port. Place PVC pipe under skimmer body and adjust to make top of skimmer level. (fig. E)

Any gaps in the back of the white mounting plate should be covered using a spray foam filler such as "Great Stuff". After the concrete collar is poured, check level of skimmer top.

Extension Collars:

Extension Collars (not included) (fig. F) are used with most inground skimmers to raise the top of the skimmer to the height of decking. The number of extension collars needed is determined by benchmark established by top of coping.

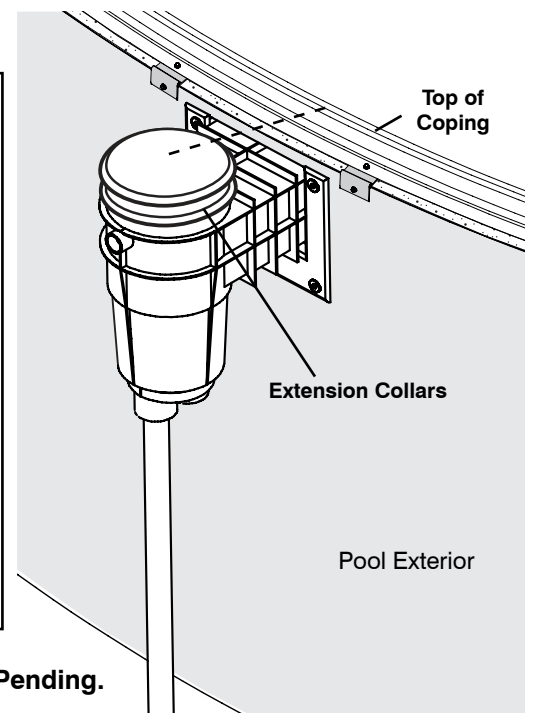
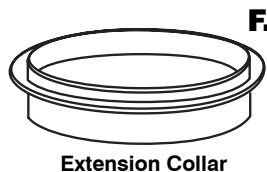

Patent Nos: 9,890,547/D837,471/D830,012/10,138,645. Other Patents Pending.

SKIMMER ASSEMBLY: STRAIGHT WALL/WIDE MOUTH SKIMMER

Mount the aluminum wide mouth skimmer mounting plate (**Fig. A**) to the inside pool wall using the included nuts and bolts, positioning the aluminum bars (**Fig. B**) on the outside of the pool wall as shown below. Keep all connections slightly loose to ensure correct skimmer placement.

IT IS CRITICAL TO MAKE SURE THE SKIMMER IS SUPPORTED BY A LENGTH OF PVC TO PREVENT SETTLING.

Mount wide mouth skimmer to aluminum skimmer mounting plate using the included screws. Depending on the style of skimmer used, you may have to pre-drill holes in the skimmer body to set all screws. Now securely tighten nuts and bolts on mounting kit and cover edges of aluminum plate with duct tape.

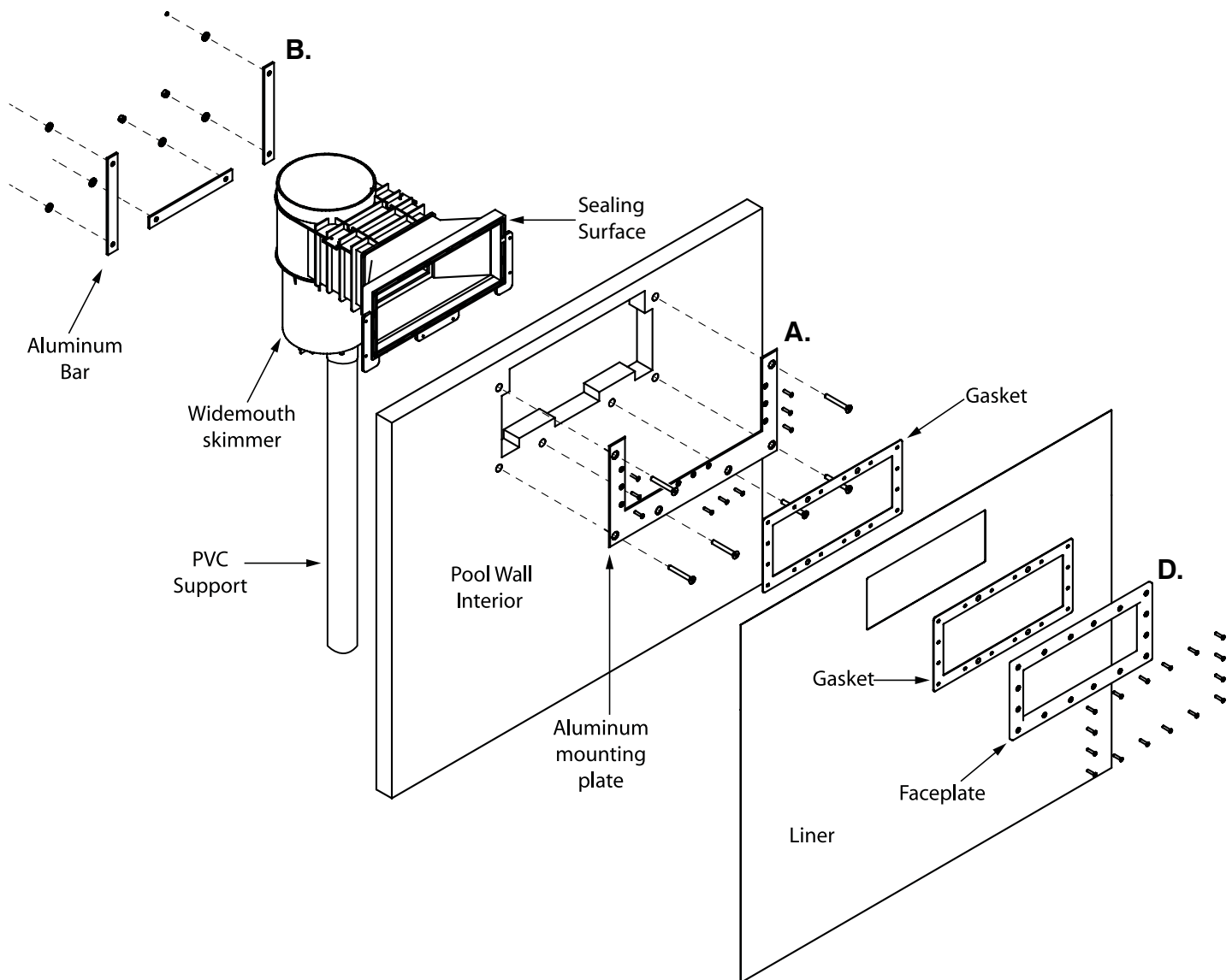

Position one wide mouth gasket (**Fig. C**) on the sealing surface of the skimmer and secure tightly with duct tape. When dropping the liner, you may want to install the liner bead around skimmer locations last, in order to avoid disturbing gasket placement.

After liner has been installed and water level approaches skimmer, prep skimmer faceplate (**Fig. D**) by lining up faceplate and gasket, and then carefully drive screws through faceplate, gasket, liner, interior gasket and into skimmer throat. Securing the corners first will help ensure correct placement.

As water level approaches skimmer, carefully cut out liner from inside of skimmer faceplate with sharp blade, making sure to avoid nicking the gaskets.

RETURN FITTING ASSEMBLY

The return fitting kit includes four parts: inlet fitting, 2 inlet plates and a back nut.

Install the inlet fitting in the inlet plate, with the inlet plates over the threads on the interior and exterior of the pool, then thread the back nut onto the fitting. **DO NOT OVERTIGHTEN.**

For additional return fittings, drill 3" hole (with 3" hole saw), 12" down from top of panel. Edges will be sharp but not in contact with liner or hands once wall fitting has been installed. Install return wall fitting per directions, firmly. Do not over tighten.

Note: For the Radiant IED light, drill hole 14" down from top of panel. Installation is identical to return fitting.

The return faceplates are attached after the liner is installed.

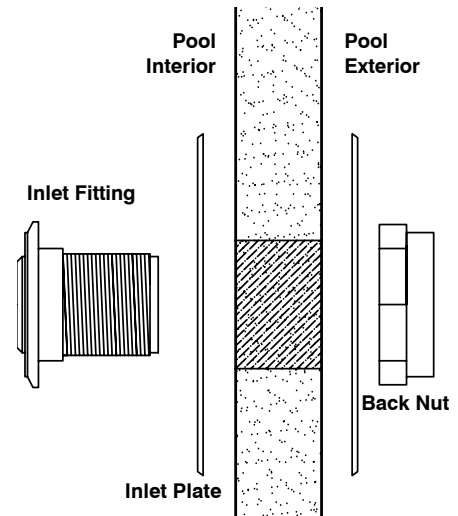

RETURN FITTING ASSEMBLY

Install leg supports for the steps. For steps supplied by Radiant Pools, instructions will be provided. If steps are purchased separately through another provider, verify compatibility by talking with a Radiant Pools representative. Be sure to check step manufacturer's instructions as the step supports will vary by manufacturer.

Position the step in the desired location. Level step, establish benchmark. The benchmark (finished height of the pool) includes the wall height, the coping and the decking (concrete, pavers, etc). Adjust height of step by aligning top of coping with top of step and plumb by checking front face of step unit with adjoining panel. See images below to determine the proper benchmark for your installation.

Once step is positioned, check levels from side to side and front to back.

Trimline Step with RCR Coping

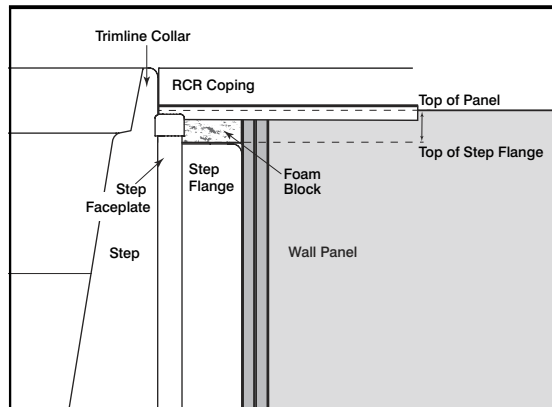

Trimline Step with Standard Coping

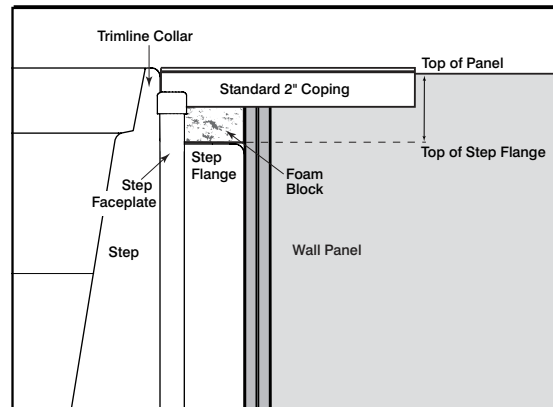

Trimline Step with Premium Coping

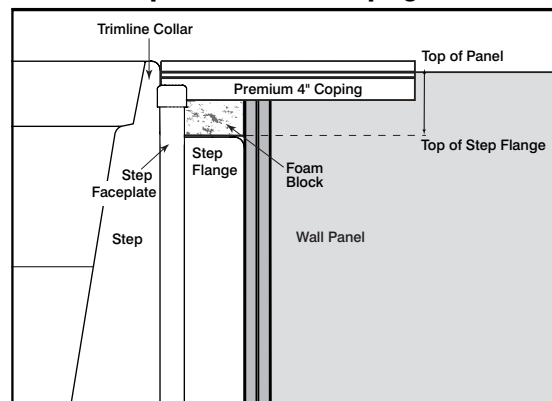

Cantilever Step with Paver Coping

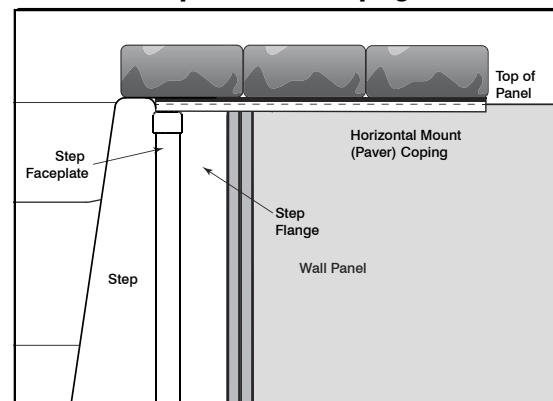

WALK-IN STEP INSTALLATION

Radius Step to Radius Wall Panel (for pool sizes 18' and smaller)

Installation Components (item # KS-XX-RWSA):

- (2) Seam Connectors
- (2) 42", 48" or 52" Standard splines for interior side of pool
- (2) each: 40 1/2" Extended T splines and 5 3/4" or 10" Standard Splines for exterior side of pool (48" or 52")
- 3/8" Carriage Bolts and Nuts; Backer Washers
- (2) A-Frames for connection to T Splines on either side of step

Assemble the stair adapter kit to the first pool panel with the standard spline on the interior side of pool and the extended T-spline on the exterior of the panel. Position the panel butting up to the step flange and mark the location of the spline stair adapter with a marker or piece of tape.

Disassemble the adapter kit and clamp the seam connector to the step flange in line with the marked outline with vise grips or C-clamps. Using a 7/16" drill bit, drill through the step flange at the holes in the seam connector. Bolt the seam connector on to the step flange using the backer washer and nut on the inside of the step flange.

Important: Keep nuts very loose until all panels are installed.

T-spline assembly / Final adjusting

The extended T-spline is installed on the exterior side of the pool, with holes to attach the the A-frame components. The short standard spline is installed on top of the T-spline. The full standard spline is installed on the interior side of the pool.

Final adjusting of the step is done after all the panels are installed and stair adapter kit nuts are tightened. Check panel joints and step ends for proper location –using the radius of the pool from the established center point of the pool.

Both pool and step must be encased in a concrete collar.

Note: Remember to remove stair gaskets and faceplates before installing the liner.

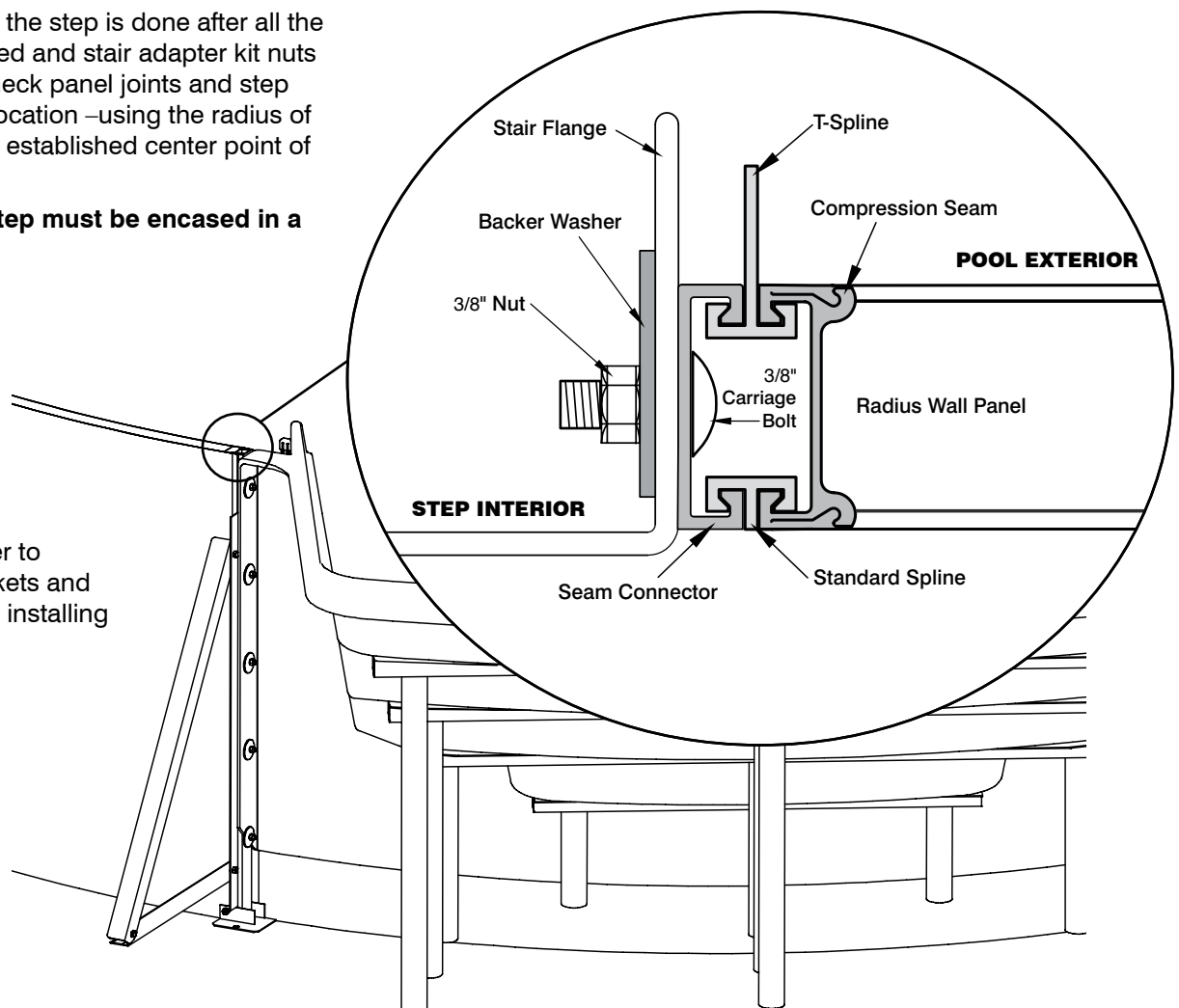

STRAIGHT PANEL TO STEP CONNECTION

Straight Wall Step Connection

1. Temporarily attach the step adapter to panel and top and bottom channels.
2. Properly align top channel with coping top of step. The panel should be vertical and the step top should be level.
3. To install, temporarily clamp (using C clamp or vise grips) step connector to step flange.
4. Use pre-drilled holes in stair connector as a guide for drilling holes through the stair flange.
5. Bolt the stair connector to step flange with backer washers and nuts on the inside of the step flange.

Important: Keep nuts very loose until all panels are installed. Final adjusting of the step is done at this time.

6. Install wall panel into bottom channel and stair adaptor. Align connection clip in bottom channel to step flange. Use hole in clip as a guide through stair adaptor and step flange. Secure with nut, bolt and backer washer.
7. Bolt back brace and install A-Frame at nearest pre-drilled hole in channel.
8. Complete installation of remaining panels.
9. Tighten all nuts, check for plumb, level and square of pool and step.

Both pool and step must be encased in a concrete collar.

Note: Remember to remove stair gaskets and faceplates before installing liner.

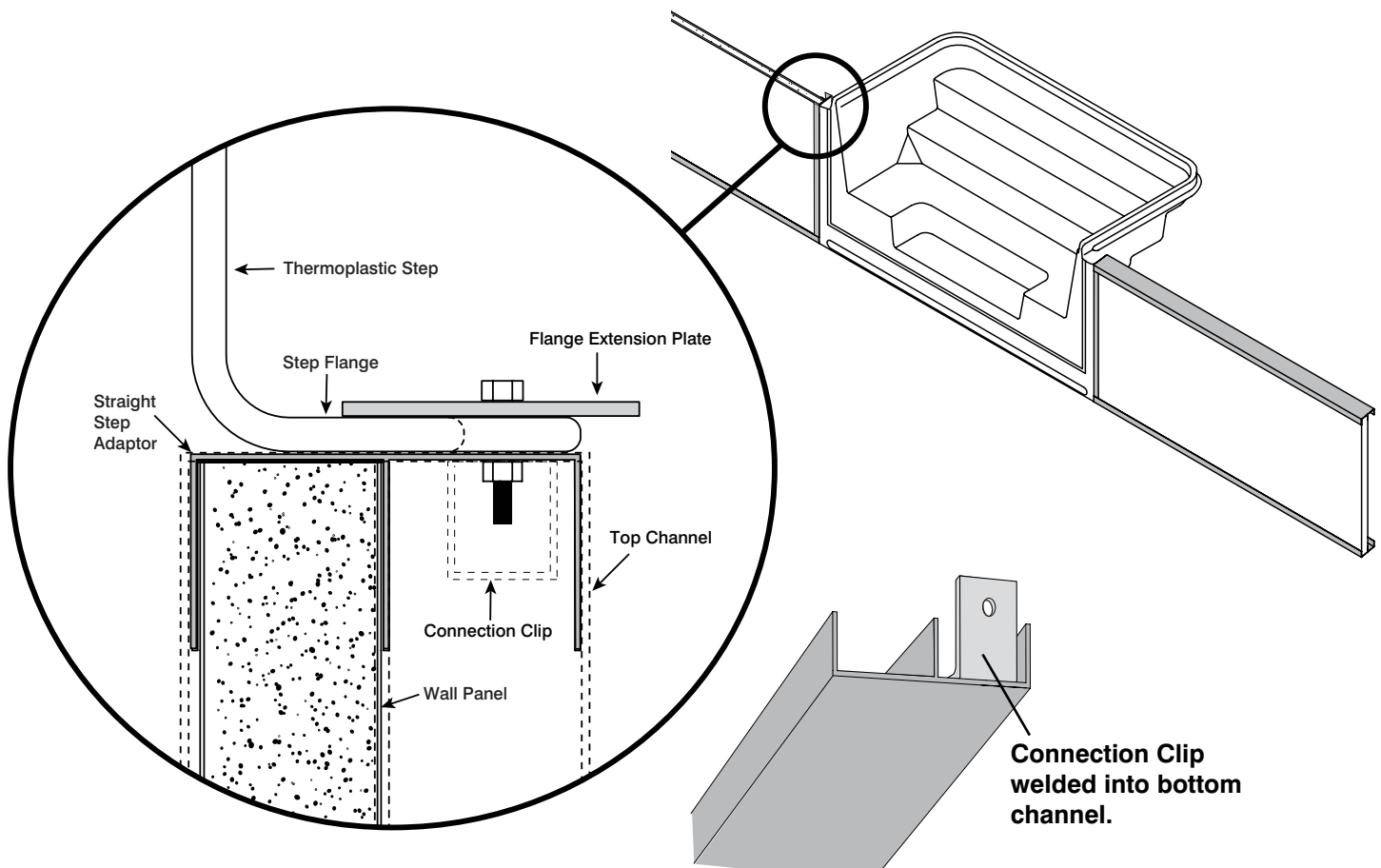

STRAIGHT PANEL TO STEP 45° CONNECTION (OPTIONAL)

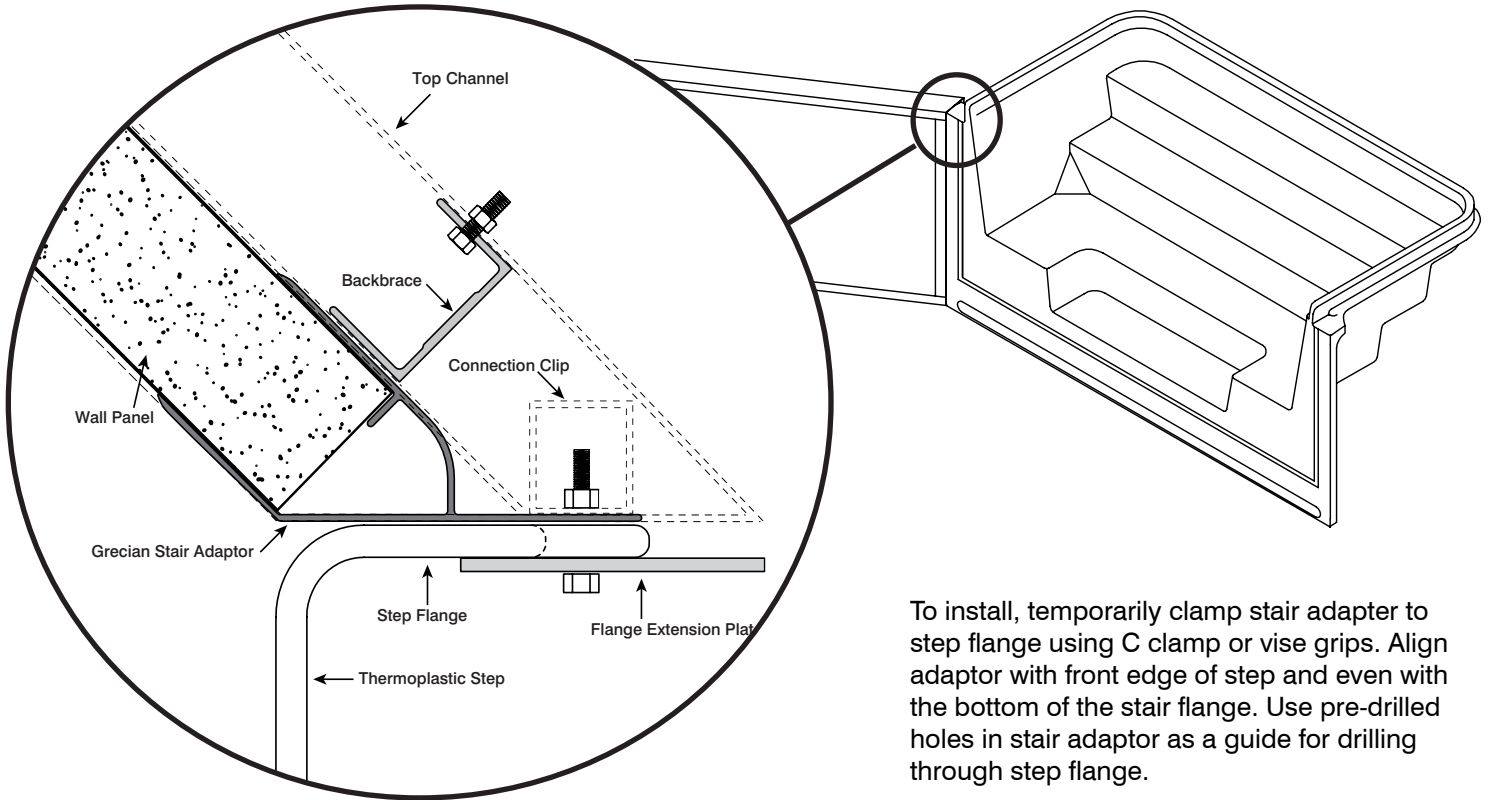

To install, temporarily clamp stair adaptor to step flange using C clamp or vise grips. Align adaptor with front edge of step and even with the bottom of the step flange. Use pre-drilled holes in stair adaptor as a guide for drilling through step flange.

Install wall panel into bottom channel and stair adaptor. Align connection clip in bottom channel to step flange. Use hole in clip as a guide through stair adaptor and step flange. Secure with nut, bolt and backer washer.

Repeat with top channel for both sides of step.

Both pool and step must be encased in a concrete collar.

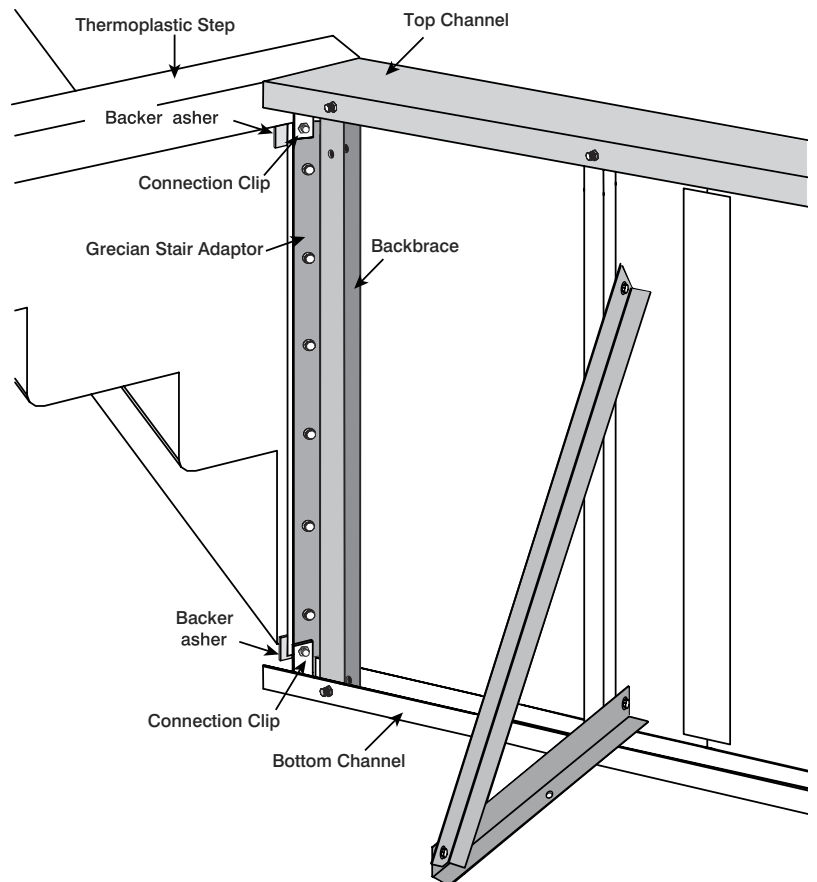

STOP!

**DO NOT PROCEED BEFORE CHECKING
FINAL CROSS MEASUREMENTS!**

All Radiant Radius Panel Pools are shipped with drawings with cross measurements. If you do not have this page, call your Radiant dealer or sales representative now!

Checking these layout dimensions is critical and cannot be skipped.

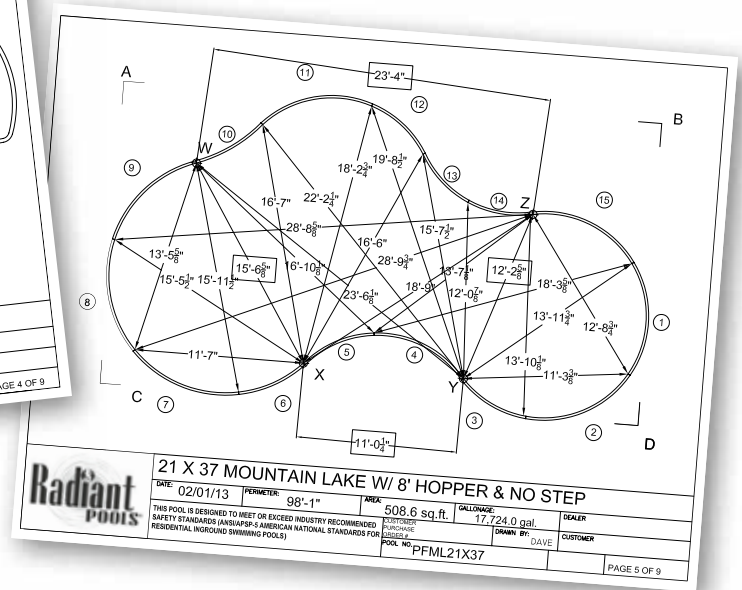
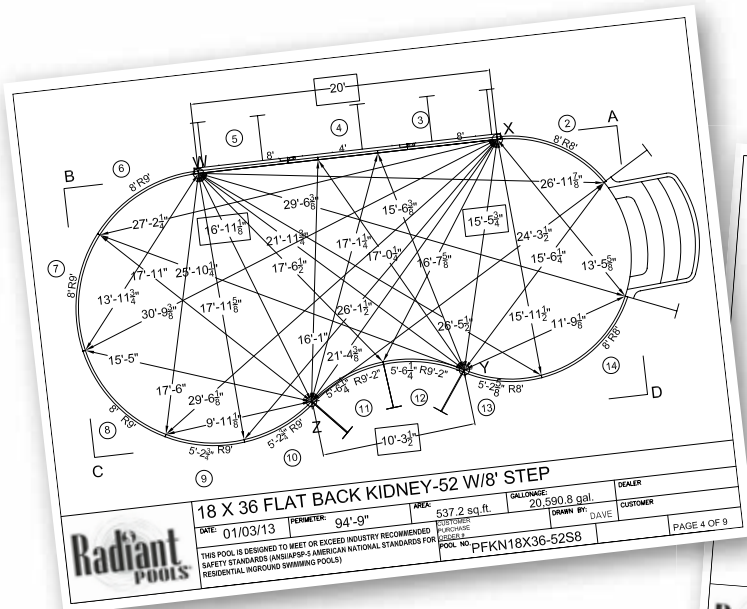

If you are off by 1/4" or more, the walls need to be adjusted before locking them into place with the concrete collar or you will have problems installing the liner.

CONCRETE COLLAR GUIDE

Check with local building codes before installing your Radiant Pool inground. Radiant Pools recommends an 8" x 12" concrete collar for 42" wall heights, 12" x 16" concrete collar for 48" and 52" wall heights. around the entire pool (**fig. 1 & 2**) and an 8" x 24" concrete pour at each A-Frame location (**fig. 3**). Concrete recommended is either #2500 pound mix or "Swimming Pool Collar Mix".

Do not pour concrete directly on the pool walls. Pour concrete away from the wall and let it flow to the wall.

If you are installing a thermoplastic walk-in step, Radiant Pools **REQUIRES** that concrete be poured behind the step and panels next to the step (**fig. 4**). Add 2.5 yards of concrete to the 'Estimating Concrete Requirements' for the concrete around the step and A-frames.

Note: Before pouring concrete collar, check with your electrician as he may want to bond the pool first.

fig. 1 Concrete Collar (42" Wall Height)

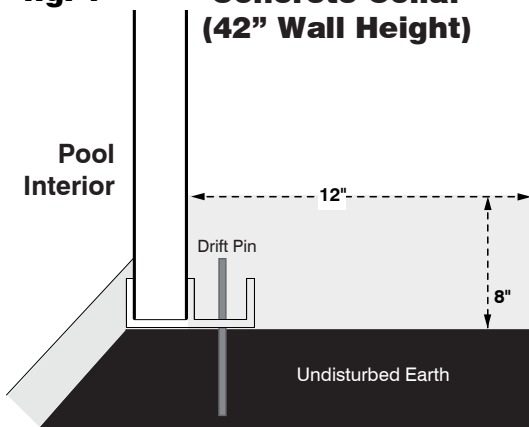

fig. 2 Concrete Collar at A-Frame Location

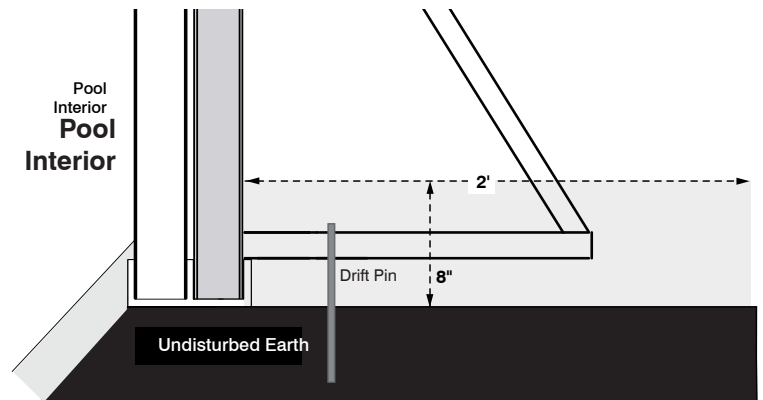

fig. 3 Concrete Collar (48" & 52" Wall Height)

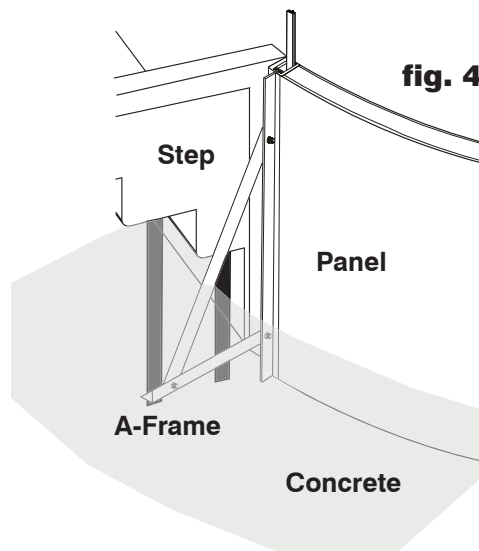
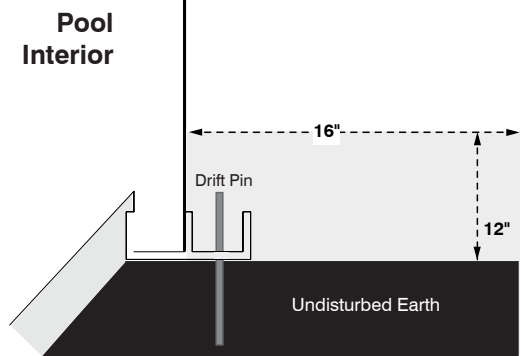

fig. 4 Concrete Required at Step Location

Note: Complete backfill is required around the step.

Estimating Concrete Requirements:

These are minimum estimating figures. It is recommended that estimates be on the high end as the excess can be poured around A-Frame. Select the appropriate size collar based on your pool wall height and combine it with your A-Frame estimate for total yards of concrete required.

8"x12" Collar (42" Wall Height): Pool Perimeter (ft.) x .04 = Yards required.

12"x16" Collar (48" & 52" Wall Height): Pool Perimeter (ft.) x .06 = Yards required.

A-Frames: Number of A-Frames x .15

Example: For a 20x40 42" Rectangle with a perimeter of 120' and 20 A-Frames the required yards would be:

$(120' \times 0.04) + (20 \text{ A-Frames} \times .15) = 7.8 \text{ yards of concrete}$

BACKFILL AND DRAINAGE

Before backfilling, check with electrician for pool bonding. Sonotubes may be installed at the time of collar pour to support the deck.

Backfill may go directly against a Radiant pool wall. Crushed stone/gravel 3/8" - 3/4" in diameter is recommended. Do not use expansive soil (clay).

Uphill run-off should be redirected around the pool incorporating a French drain concept using a perforated drain pipe and water relief area away from the pool and other structures.

Backfill as the pool is filling with water, manually compacting every 8"-12" (Do not use compacting machinery.) Hand backfill around skimmers, lights and inlets. Be sure that piping is buried, but not crushed.

If backfilling completely before pool is filled, the straight walls must be cross braced at the top, inside the pool. This is not the recommended method of backfilling your Radiant Pool.

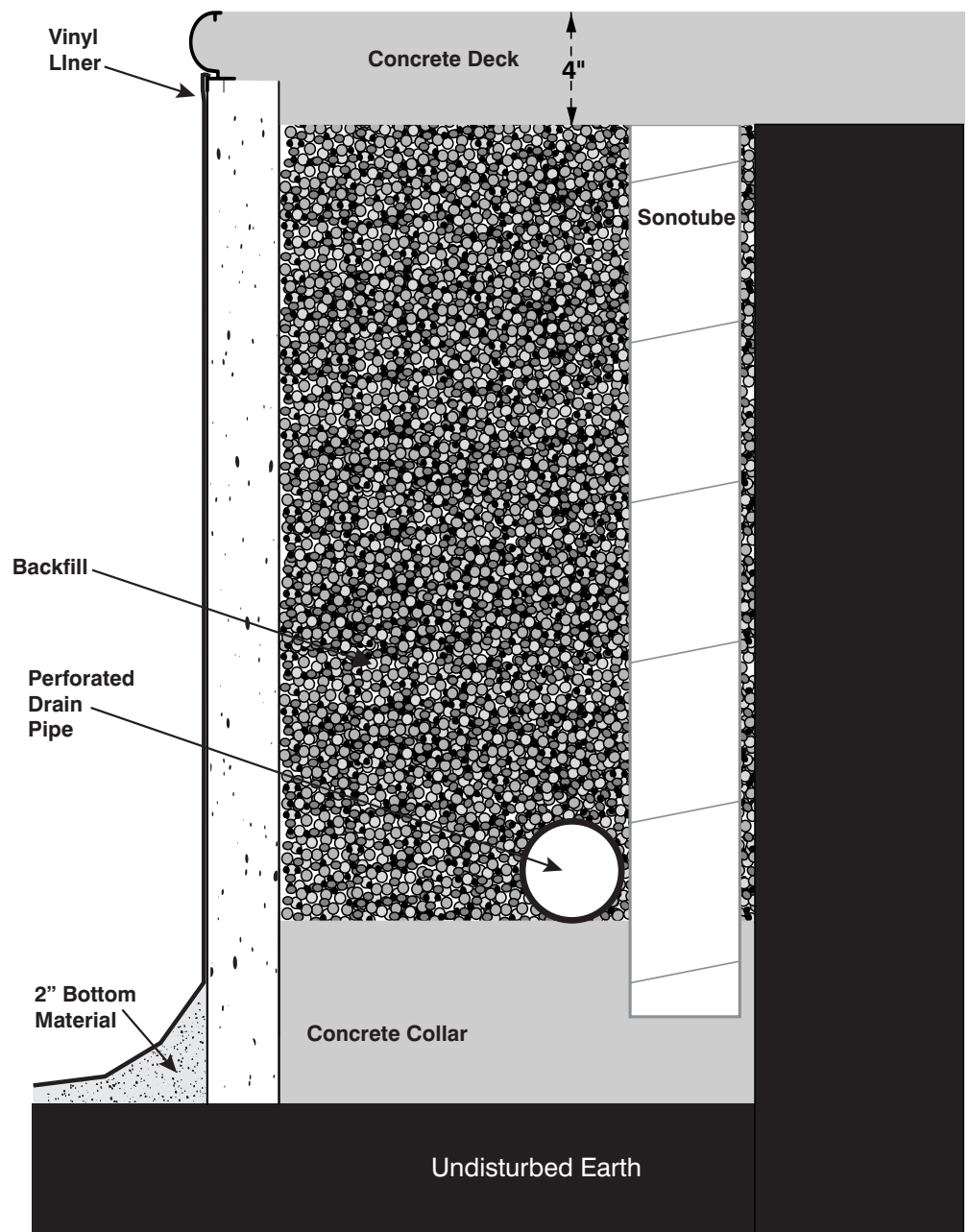

INSTALLING FACEPLATES

Once the water level reaches 2"-3" from the return and skimmer, install the faceplates. Carefully locate the screw holes for each opening. Once located, carefully puncture the liner with an ice pick or nail. Attach skimmer faceplate with 1" screws and hand tighten evenly in order as shown in skimmer faceplate image below. When installing return faceplate, hand tighten each screw by a half turn, alternating between each, until all are tightened evenly. This ensures uniform compression of sealing gaskets. Using a razor knife, carefully trim the liner from inside of the openings for the skimmer and return. When done, install the eyeball into the return.



Locate screw holes for faceplate.

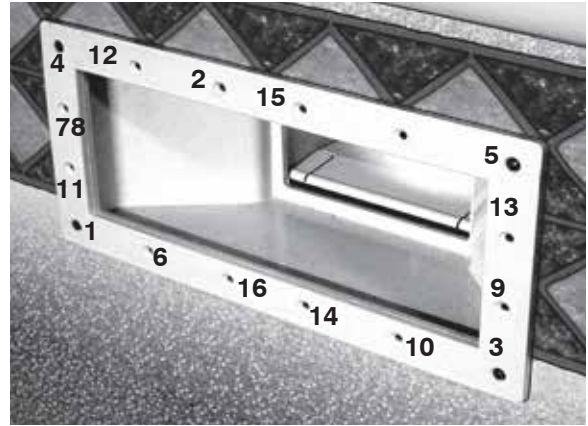

Skimmer faceplate installed w/ screw tightening sequence



Trim liner from return opening.



Return faceplate installed.

COMPLETING INSTALLATION

Please refer to manufacturers' installation instructions for all other installation components, including liner.

Radiant

A Latham Pool Company

**440 North Pearl Street
Albany, NY 12207**

1-800-RADIANT

www.radiantpools.com